

Service Manual

COMPACT
disc
DIGITAL AUDIO

MASH*1
multi-stage noise shaping

*2  **DOLBY B NR**

CD Stereo System
SA-CH74

Colour

(K) ... Black Type

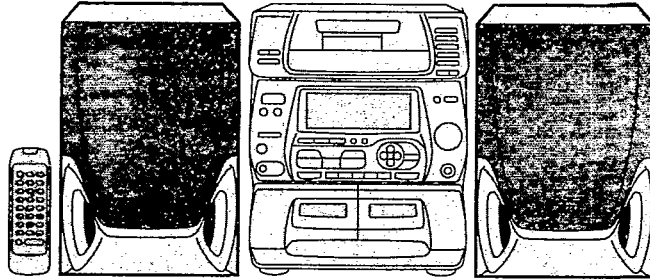

Remote Control
Transmitter

SB-CH74

SA-CH74

SB-CH74

TAPE SECTION : AR2 MECHANISM SERIES
CD SECTION : RAE0150Z TRAVERSE DECK SERIES

Specifications

Amplifier Section

| | |
|---------------------------------|---------------------------------------|
| 1 kHz continuous power output | |
| Both channels driven | 2 x 35 W (THD 1%, 4 Ω) |
| RMS | 2 x 50 W (THD 10%, 4 Ω) |
| Total harmonic distortion | |
| Half power at 1 kHz | 0.06 % (4 Ω) |
| Frequency response | |
| AUX | 60 Hz – 20 kHz (–3 dB) |
| Input sensitivity and impedance | |
| AUX | 250 mV, 28 kΩ |
| MIC | 0.6 mV, 680 Ω |
| Tone controls | |
| 6 EQ SPACE | HEAVY, CLEAR, SOFT, DISCO, LIVE, HALL |
| V. BASS (volume at –30 dB) | 63 Hz, 7 dB |
| Load impedance | 4 Ω |

FM Tuner Section

| | |
|----------------------------|--------------------|
| Frequency range | 87.50 – 108.00 MHz |
| Sensitivity | 23.3 dBf |
| Total harmonic distortion | |
| MONO | 0.3 % |
| STEREO | 0.5 % |
| S/N (MONO) | 60 dB |
| Image rejection at 98 MHz | 35 dB |
| Stereo separation at 1 kHz | 35 dB |
| Antenna terminal(s) | 75 Ω (unbalanced) |

AM Tuner Section

| | |
|--------------------------|----------------|
| Frequency range | |
| MW | 522 – 1611 kHz |
| LW | 144 – 288 kHz |
| Sensitivity (for 500 mW) | |
| MW (at 999 kHz) | 250 μV/m |
| LW (at 252 kHz) | 500 μV/m |

*1

MASH is a trademark of NTT.

Area

| Suffix for Model No. | Area | Colour |
|----------------------|--------------------|--------|
| (E) | Continental Europe | (K) |
| (EB) | Great Britain | |
| (EG) | Germany and Italy | |

| System | Music Center | Speaker |
|--------------|--------------|-------------------------------|
| SC-CH74 (E) | SA-CH74 (E) | SB-CH74 (E) (made in PAES) |
| SC-CH74 (EB) | SA-CH74 (EB) | |
| SC-CH74 (EG) | SA-CH74 (EG) | |

Cassette Deck Section

| | |
|---|---|
| Track system | 4 track, 2 channel |
| Heads | |
| Playback | Solid permalloy head (Rotary head) |
| Record/playback | Solid permalloy head (Rotary head) |
| Erase | Double gap ferrite head |
| Motor | DC servo motor |
| Recording system | AC bias 100 kHz |
| Erasing system | AC erase 100 kHz |
| Tape speed | 4.8 cm/s (17 1/8 ips) |
| Frequency response [(+3 dB, –6 dB) at deck out] | |
| NORMAL | 35 Hz – 14 kHz |
| HIGH | 35 Hz – 14 kHz |
| S/N (HIGH POSITION) | |
| Dolby NR off | 50 dB (A weighted) |
| Dolby NR on | 60 dB (CCIR) |
| Wow and flutter | 0.18 % (WRMS) |
| Fast forward and rewind times | Approx. 120 seconds with C-60 cassette tape |

CD Section

| | |
|-------------------------|-------------------------------|
| Sampling frequency | 44.1 kHz |
| Decoding | 16 bit linear |
| Beam source/wave length | Semiconductor laser / 780 nm |
| Number of channels | Stereo |
| Frequency response | 20 Hz – 20 kHz (+1 dB, –2 dB) |
| S/N (CD UNIT OUT) | 95 dB (JIS. A) |
| Wow and flutter | Below measurable limit |
| Digital filter | 8 fs |
| D/A converter | MASH (1 bit DAC) |

*2 Dolby noise reduction manufactured under license from Dolby Laboratories Licensing Corporation. "Dolby" and the double-D symbol are trade marks of Dolby Laboratories Licensing Corporation.

© 1996 Matsushita Electronics (S) Pte. Ltd.
All rights reserved. Unauthorized copying and distribution is a violation of law.

Panasonic[®]

⚠ WARNING

This service information is designed for experience repair technicians only and is not designed for use by the general public. It does not contain warnings or cautions to advise non-technical individuals of potential dangers in attempting to service a product. Products powered by electricity should be serviced or repaired only by experienced professional technicians. Any attempt to service or repair the product or products dealt with in this service information by anyone else could result in serious injury or death.

■ General

| | |
|-------------------------------|---|
| Power consumption | 150 W |
| Power supply | AC 50 Hz, 230 V (E, EG) AC 50 Hz, 230 – 240 V (EB) |
| Dimensions (W x H x D) | 270 x 331.5 x 331 mm |
| Weight | 7.6 kg |

Notes :

- Specifications are subject to change without notice. Weight and dimensions are approximate.
- Total harmonic distortion is measured by the digital spectrum analyzer.

■ Contents

| | Page | | Page |
|---|---------|--|---------|
| BEFORE REPAIR AND ADJUSTMENT | 2 | BLOCK DIAGRAM | 23 ~ 29 |
| HANDLING PRECAUTIONS FOR TRAVERSE DECK | 2 | PRINTED CIRCUIT BOARD | 30 ~ 38 |
| PROTECTION CIRCUITRY | 3 | SCHEMATIC DIAGRAM | 39 ~ 55 |
| PRECAUTION OF LASER DIODE | 3 | TROUBLESHOOTING GUIDE | 56 |
| CAUTION FOR AC MAINS LEAD | 4 | MECHANISM PARTS LIST | 57 |
| BEFORE MOVING OR SHIPPING THIS UNIT | 5 | CD LOADING UNIT PARTS LIST | 57 |
| OPERATION CHECKS AND MAIN COMPONENT REPLACEMENT | 5 ~ 10 | MECHANISM PARTS LOCATION (RAA3404) | 58 ~ 59 |
| SELF-DIAGNOSTIC DISPLAY FUNCTION | 11 ~ 12 | CABINET PARTS LOCATION | 60 ~ 61 |
| CD TEST MODE FUNCTION | 13 | CD LOADING UNIT PARTS LOCATION | 62 |
| RELIABILITY TEST MODE FOR CD/CD CHANGER | 14 | REPLACEMENT PARTS LIST | 63 ~ 66 |
| MEASUREMENTS AND ADJUSTMENTS | 15 ~ 16 | RESISTORS & CAPACITORS | 66 ~ 71 |
| TERMINAL FUNCTION OF ICs | 17 ~ 19 | PACKING MATERIALS & ACCESSORIES | 72 |
| WIRING CONNECTION DIAGRAM | 20 ~ 21 | PACKAGING | 72 |
| TERMINAL GUIDE OF ICs, TRANSISTORS AND DIODES.. | 22 | | |

■ Before Repair and Adjustment

Disconnect AC power, discharge both Power Supply Capacitors C522 and C523 through a 10Ω, 5W resistor to ground. DO NOT SHORT-CIRCUIT DIRECTLY (with a screwdriver blade, for instance), as this may destroy solid state devices. After repairs are completed, restore power gradually using a variac, to avoid overcurrent. Current consumption at 230V, 50 Hz in NO SIGNAL mode should be ~200mA.

■ Handling Precautions for Traverse Deck

The laser diode in the traverse deck (optical pickup) may break down due to potential difference caused by static electricity of clothes or human body. So, be careful of electrostatic breakdown during repair of the traverse deck (optical pickup).

• Handling of traverse deck (optical pickup)

- Do not subject the traverse deck (optical pickup) to static electricity as it is extremely sensitive to electrical shock.
- To prevent the breakdown of the laser diode, an antistatic shorting pin is inserted into the flexible board (FPC board). When removing or connecting the short pin, finish the job in as short time as possible.
- Take care not to apply excessive stress to the flexible board (FPC board).
- Do not turn the variable resistor (laser power adjustment). It has already been adjusted.

• Grounding for electrostatic breakdown prevention

- Human body grounding**
Use the anti-static wrist strap to discharge the static electricity from your body.
- Work table grounding**
Put a conductive material (sheet) or steel sheet on the area where the traverse deck (optical pickup) is placed, and ground the sheet.

Caution :

The static electricity of your clothes will not be grounded through the wrist strap. So, take care not to let your clothes touch the traverse deck (optical pickup).

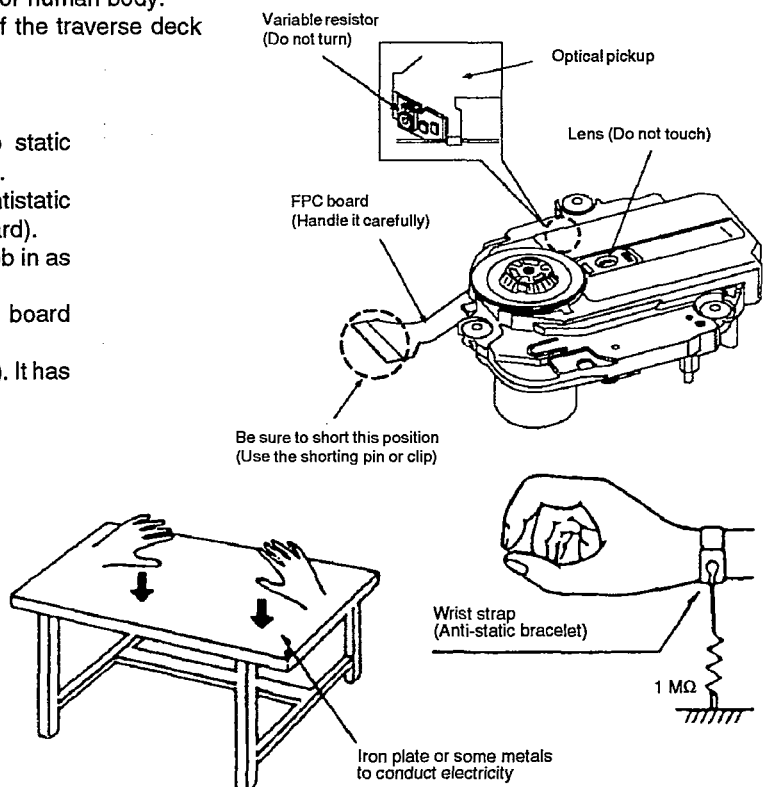

■ Protection Circuitry

The protection circuitry may have operated if either of the following conditions are noticed:

- No sound is heard when the power is turned on.
- Sound stops during a performance.

The function of this circuitry is to prevent circuitry damage if, for example, the positive and negative speaker connection wires are "shorted", or if speaker systems with an impedance less than the indicated rated impedance of the amplifier are used.

■ Precaution of Laser Diode

CAUTION : This product utilizes a laser diode with the unit turned "ON", invisible laser radiation is emitted from the pick up lens.
Wavelength : 780 nm
Maximum output radiation power from pick up : 100 μ W/VDE

Laser radiation from pick up unit is safety level, but be sure the followings:

1. Do not disassemble the optical pick up unit, since radiation from exposed laser diode is dangerous.
2. Do not adjust the variable resistor on the pick up unit. It was already adjusted.
3. Do not look at the focus lens using optical instruments.
4. Recommend not to look at pick up lens for a long time.

ACHTUNG: Dieses produkt enthält eine laserdioden. Im eingeschalteten zustand wird unsichtbare laserstrahlung von der lasereinheit abgestrahlt.

Wellenlänge : 780nm
Maximale strahlungsleistung der lasereinheit :100 μ W/VDE

Die strahlung an der lasereinheit ist ungefährlich, wenn folgende punkte beachtet werden:

1. Die lasereinheit nicht zerlegen, da die strahlung an der freigelegten laserdioden gefährlich ist.
2. Den werkseitig justierten einstellregler der lasereinheit nicht verstellen.
3. Nicht mit optischen instrumenten in die fokussierlinse blicken.
4. Nicht über längere zeit in die fokussierlinse blicken.

ADVARSEL: I dette a apparat anvendes laser.

CAUTION!

THIS PRODUCT UTILIZES A LASER.
USE OF CONTROLS OR ADJUSTMENTS OR PERFORMANCE OF PROCEDURES OTHER THAN THOSE SPECIFIED HEREIN
MAY RESULT IN HAZARDOUS RADIATION EXPOSURE.

■ Use of Caution Labels

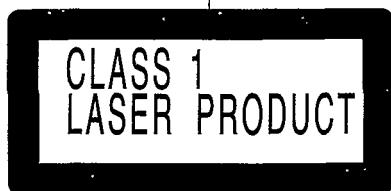
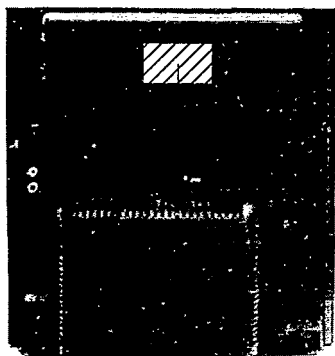

LUOKAN 1 LASERLAITE
KLASS 1 LASER APPARAT

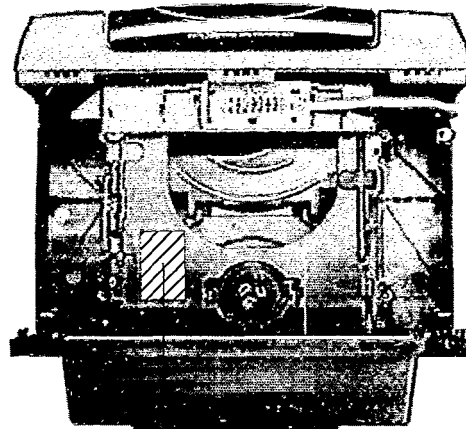

| | |
|----------|--|
| DANGER | IRVISIBLE LASER RADIATION WHEN OPEN. AVOID DIRECT EXPOSURE TO BEAM. |
| ADVARSEL | USYKIG LASERSTRÅLING VED ÅBNING. NÅR SIKKERHEDSFRYDEDE ER LØSE AF FUNKTIONEL UND GÅ LØSSETTELSE FOR STRÅLING. |
| VARO! | AVATTAESSA JA SUOJALUKITUS OHITETTAESSA OLET ALTTIINA NÄKYVÄTÖNTÄ LASERSTRÄLLELLE. ÄLÄ KATSO SÄTEESSEEN. |
| VARNING | OSYKIG LASERSTRÅLING NÅR DEKSEL ÅPNES OG SIKKERHEDSLÅS BRYTES. UNNGÅ EKSPONERING FOR STRÅLEN. |
| ADVARSEL | USYKIG LASERSTRÅLING NÅR DEKSEL ÅPNES OG SIKKERHEDSLÅS BRYTES. UNNGÅ EKSPONERING FOR STRÅLEN. |
| VORSICHT | UNSICHTBARE LASERSTRÅHLUNG, WENN ABDECKUNG GEÖFFNET. NICHT DEM STRAHLEN AUSSETZEN. |

■ Caution for AC Mains Lead

[For [EB] area.]

For your safety, please read the following text carefully.

This appliance is supplied with a moulded three pin mains plug for your safety and convenience.

A 5-ampere fuse is fitted in this plug.

Should the fuse need to be replaced please ensure that the replacement fuse has a rating of 5-ampere and that it is approved by ASTA or BSI to BS1362.

Check for the ASTA mark  or the BSI mark  on the body of the fuse.

If the plug contains a removable fuse cover you must ensure that it is refitted when the fuse is replaced.

If you lose the fuse cover, the plug must not be used until a replacement cover is obtained.

A replacement fuse cover can be purchased from your local dealer.

CAUTION !

IF THE FITTED MOULDED PLUG IS UNSUITABLE FOR THE SOCKET OUTLET IN YOUR HOME THEN THE FUSE SHOULD BE REMOVED AND THE PLUG CUT OFF AND DISPOSED OFF SAFELY.

THERE IS A DANGER OF SEVERE ELECTRICAL SHOCK IF THE CUT OFF PLUG IS INSERTED INTO ANY 13-AMPERE SOCKET.

If a new plug is to be fitted, please observe the wiring code as shown below.

If in any doubt please consult a qualified electrician.

IMPORTANT

The wires in this lead are coloured in accordance with the following code:

Blue: Neutral

Brown: Live

As the colours of the wires in the mains lead of this appliance may not correspond with the coloured markings identifying the terminals in your plug, proceed as follows:

The wire which is coloured BLUE must be connected to the terminal in the plug which is marked with the letter N or coloured BLACK.

The wire which is coloured BROWN must be connected to the terminal in the plug which is marked with the letter L or coloured RED.

Under no circumstances should either or these wires be connected to the earth terminal of the three pin plug, marked with the letter E or the Earth symbol \perp .

Before use

Remove the connector cover as follows.

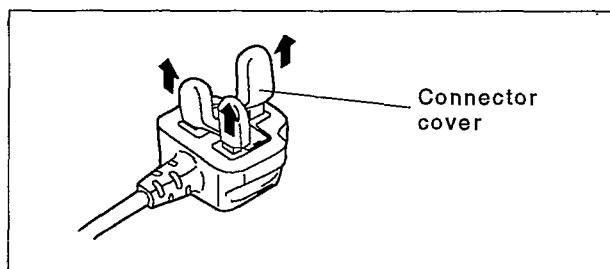

How to replace the fuse

1. Remove the fuse cover with a screwdriver.

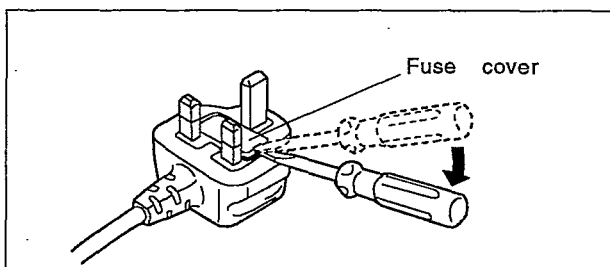

2. Replace the fuse and attach the fuse cover.

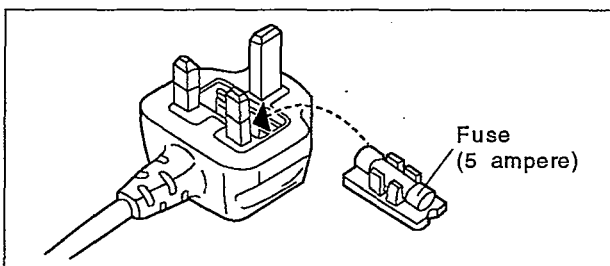

■ Operation Checks and Main Component Replacement Procedures

1. This section describes procedures for checking the operation of the major printed circuit boards and replacing the main components.
2. For reassembly after operation checks or replacement, reverse the respective procedures. Special reassembly procedures are described only when required.
3. Select items from the following index when checks or replacement are required.
4. Refer the Parts No. on the page of "Main Component Replacement Procedures", if necessary.

• Contents

| | page |
|--|-------|
| • Disassembly Procedures | |
| 1. Removal of the CD Changer Unit | 5 |
| 2. Disassembly of the Traverse Unit | 6 |
| 3. Disassembly of the CD Changer Unit | 6 & 7 |
| • Assembly of the CD Changer Unit | 7 & 8 |
| • Checking Procedure for each major P.C.B. | |
| 1. Checking of the Servo P.C.B. | 8 |
| 2. Checking of the Main, Tuner, Panel and Deck P.C.B. | 9 |
| • Main Component Replacement Procedures | |
| 1. Replacement of the Traverse Deck | 9 |
| 2. Replacement of the Power Amplifier IC and Regulator Transistors | 10 |

Warning : This product uses a laser diode. Refer to caution statements on page 3.

ACHTUNG : • Die lasereinheit nicht zerlegen.
• Die lasereinheit darf nur gegen eine vom hersteller spezifizierte einheit ausgetauscht werden.

■ Removal of the CD Changer Unit

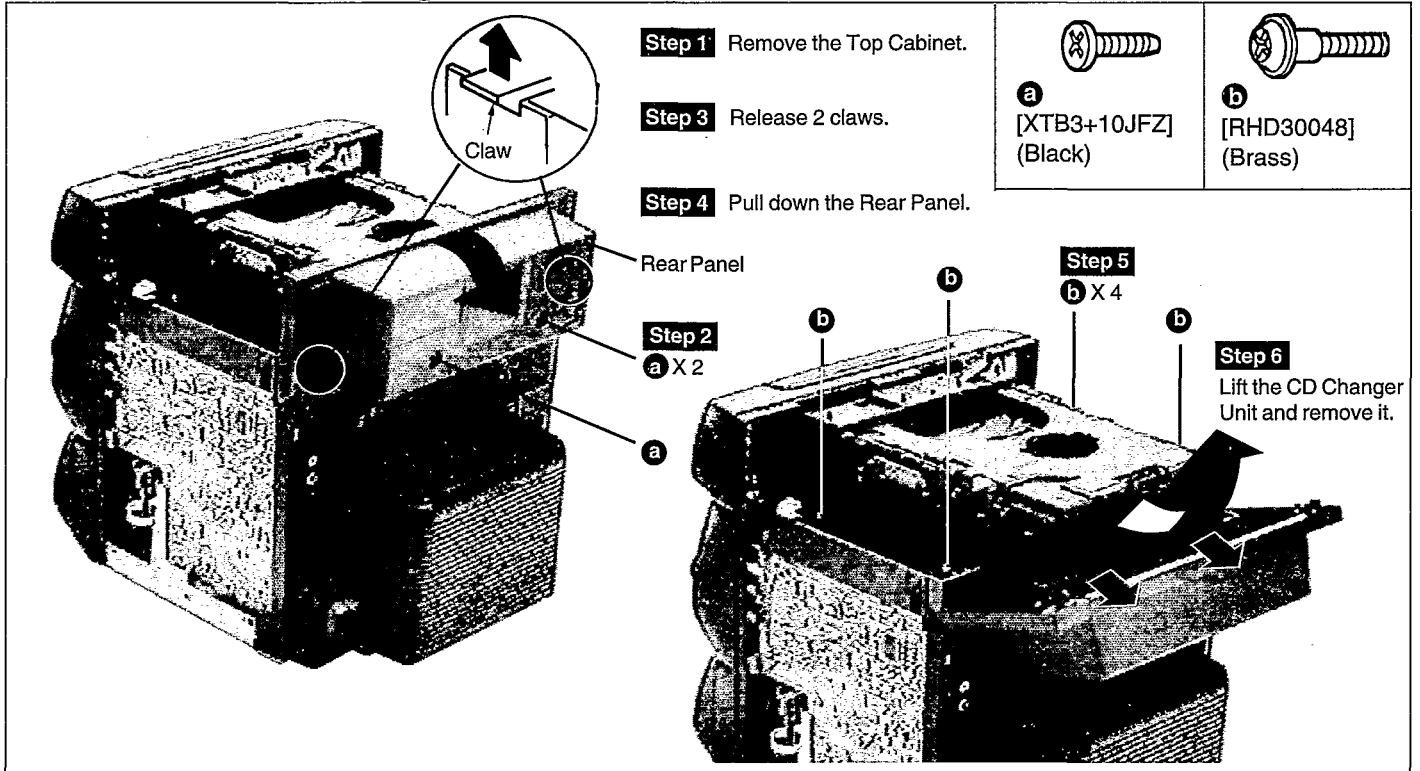

■ Before Moving or Shipping This Unit

Before moving or shipping this system:
Prepare the system as described below to prevent damage to the mechanism.

1. Remove all CDs.
2. Press CD.
3. Hold down stop button (■) for 2 seconds and then without releasing it, hold down both it and DISC 5 for 2 more seconds.
(This will turn OFF the power and set the so-called "shipping mode".)
4. Unplug the system.

Avoid strong vibrations or impact while moving the equipment. The shipping mode will turn OFF automatically when you turn the power ON the next time.

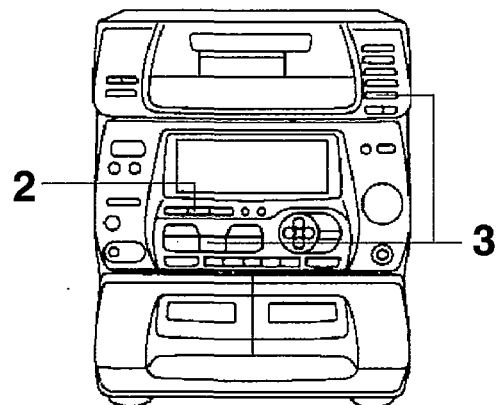

Disassembly of the Traverse Unit

Step 1 Follow the procedures in 'Remove of the CD Changer Unit' (Step 1 ~ Step 6.).

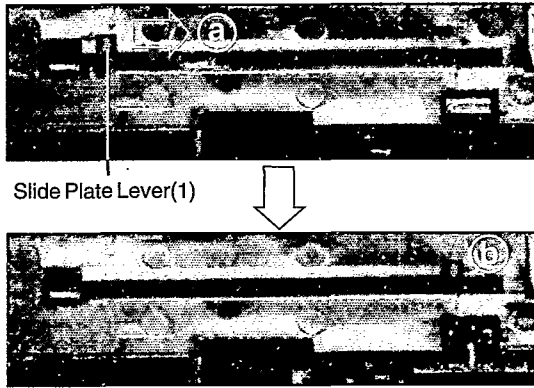

Slide Plate Lever(1)

Bottom view of CD Changer Unit

Traverse unit

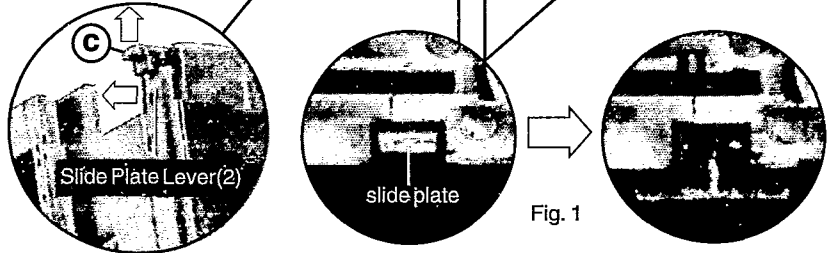

Step 2

Move the Slide Plate Lever(1) in the direction of arrow (a) to the position (b) and hold it, then lift up the stopper (c) until the Slide Plate Lever(2) eject out. Now the 3 slide plate will be open as shown in the figure 1 on the right and the traverse unit can be removed.

Disassembly of the CD Changer Unit

Step 1 Follow the procedures in 'Remove of the CD Changer Unit' (Step 1 ~ Step 6.).

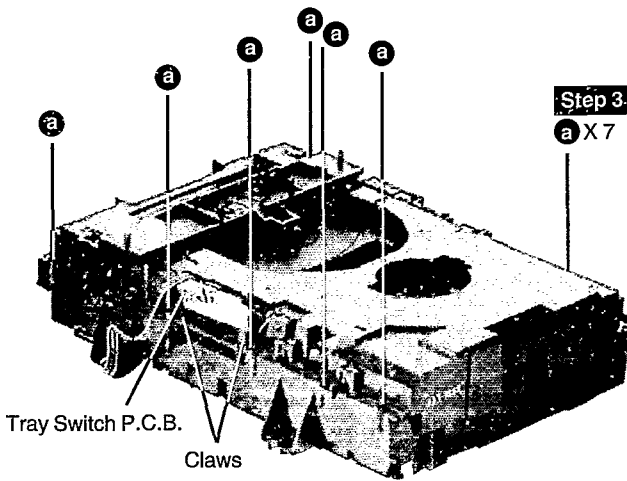

Step 3
a X 7

Step 2 Remove the Tray Switch P.C.B.

Step 4 Remove the Mechanism Cover Ass'y.

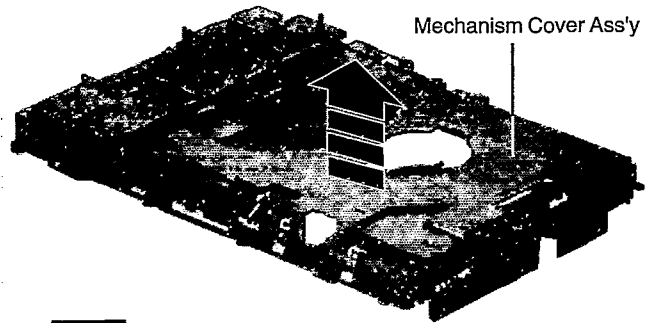

Step 5

Remove the Disc Tray sided on the Mechanism Base Ass'y.

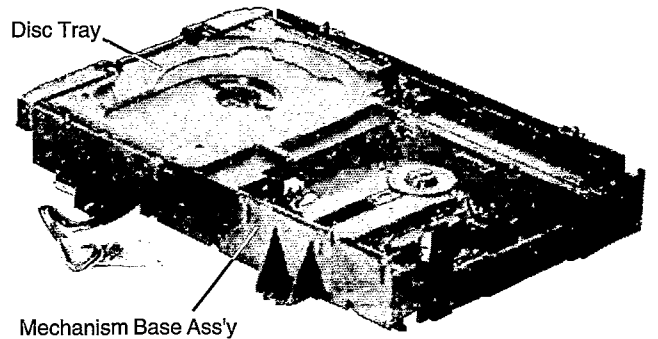

a
[XTB3+10JFZ]
(Black)

Step 6

Unlock the Base Lock Lever in the direction of arrow (a).

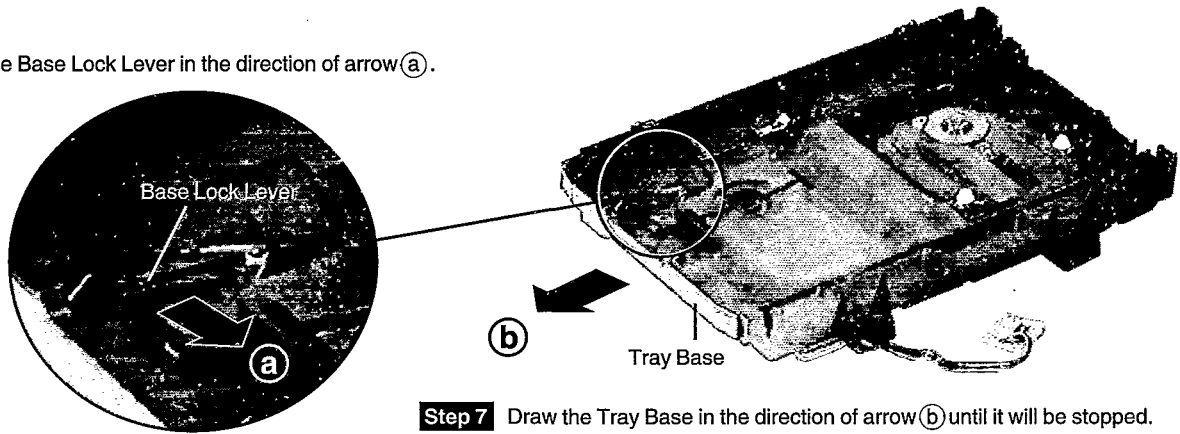

Step 7

Draw the Tray Base in the direction of arrow (b) until it will be stopped.

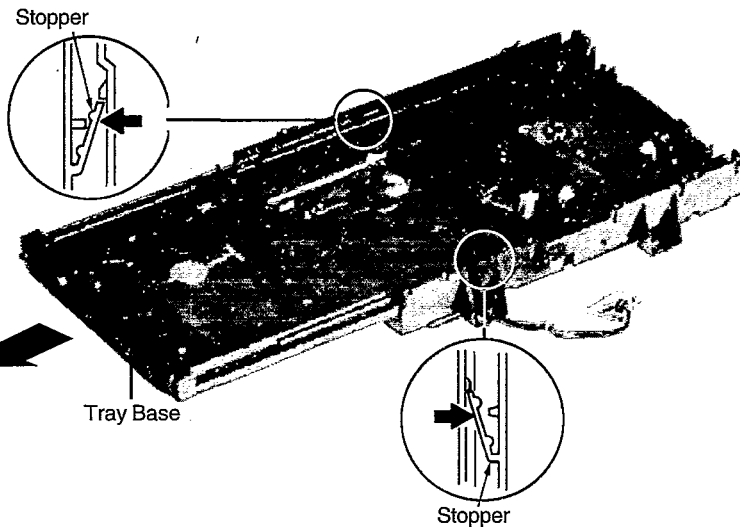

Step 8

Release 2 stoppers manually and pull out the Tray Base in the direction of arrow (c).

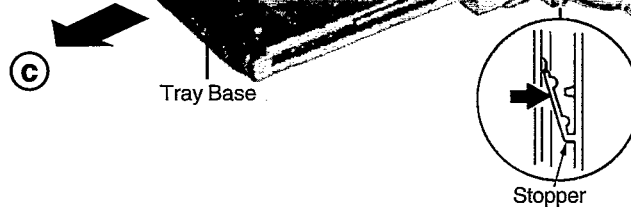

Assembly of the CD Changer Unit

Step 1

Move the Drive Rack in the direction of arrow (a) to the position as shown in the diagram below and the Carrier Lever in the direction of arrow (b) fully until the Carrier Lever is locked.

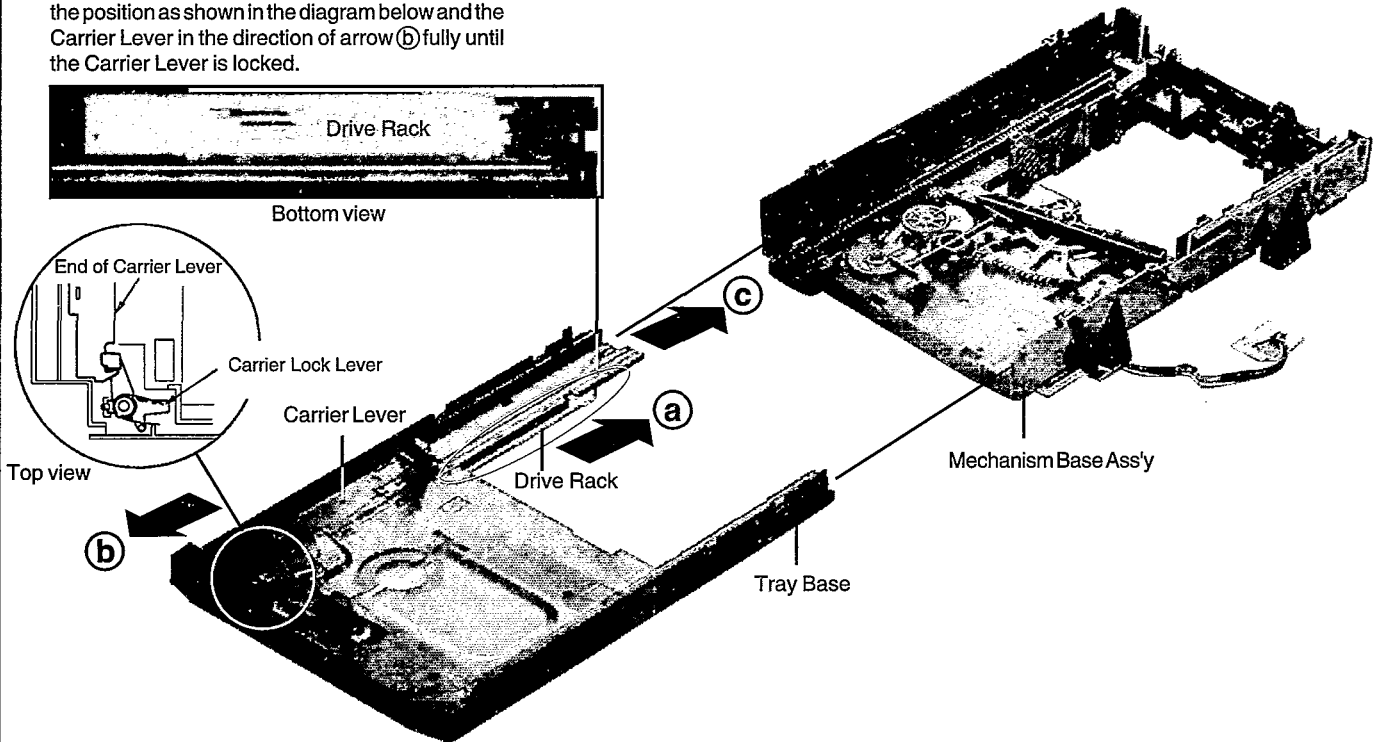

Step 2
While holding the Drive Rack and Carrier Lever, insert the Tray Base on the Mechanism Base in the direction of arrow (C) until the Tray Base stops as shown in figure 1. Release only the Carrier Lever and push the Tray Base together with the Drive Rack. After engaging the gear, release the Drive Rack which held and feed the Tray Base slowly.

Step 3
Draw the Tray Base in the direction of arrow (D) to the end until it stops. Make sure the mark '▽' on the Tray Base is aligned with the mark '△' on the Drive Rack as shown in figure 2 before closing the Tray Base. (In case that the statement above is not operated, draw the Tray Base again from step 2)

■ Checking Procedure for each major P.C.B.

1. Checking of the Servo P.C.B.

Step 1 Follow the procedures in 'Disassembly of the Traverse Unit' (Step 1 ~ Step 2).

Step 2
Slide in the Traverse Unit into a slot on the top of the CD Changer Unit and then stand it.

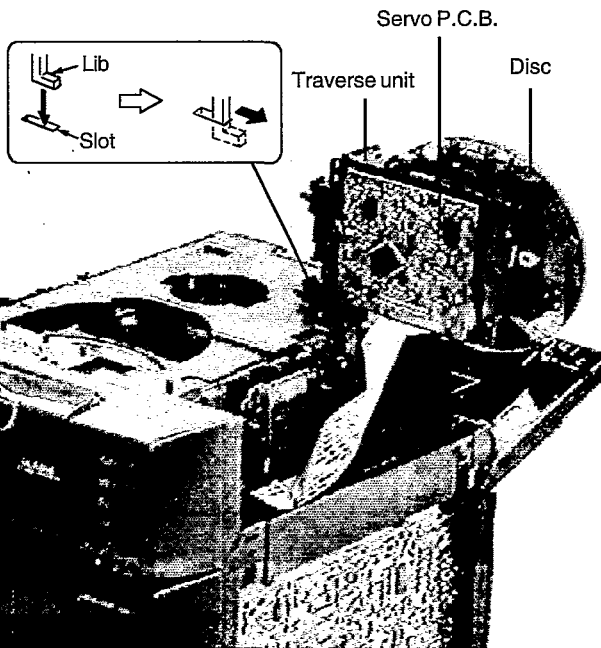

Step 3
Attach the disc and clasper with magnet to the Traverse Unit as shown in the diagram on the left, then check the Servo P.C.B. (Refer to page 13 of how to check the CD Unit without connecting to the CD Changer Loading Mechanism.)

2. Checking of the Main, Tuner, Panel and Deck P.C.B.

Step 1 Follow the procedures in 'Removal of the CD Changer Unit' (**Step 1** ~ **Step 4**).

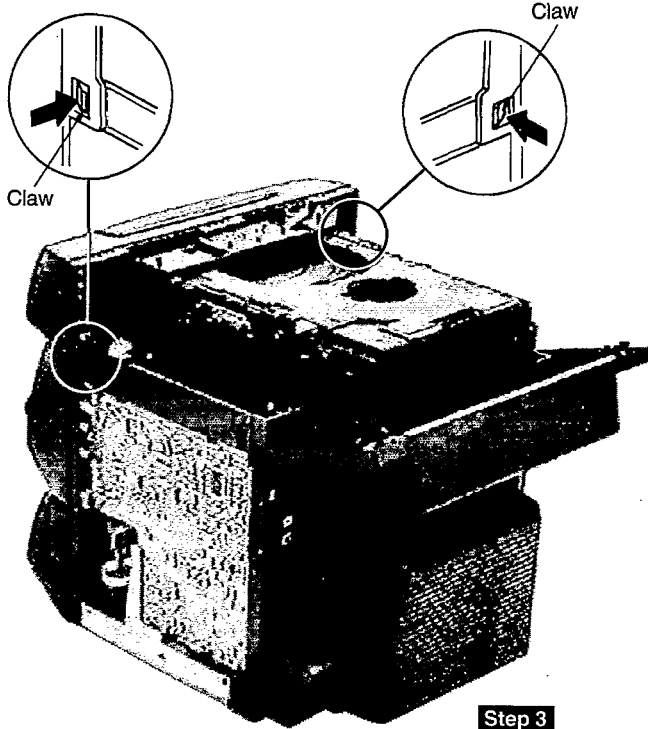

Step 2

Remove the CD Changer Chassis and CD Changer Unit with releasing the claws. (Put the CD Changer Chassis and Unit to the left side of the set)

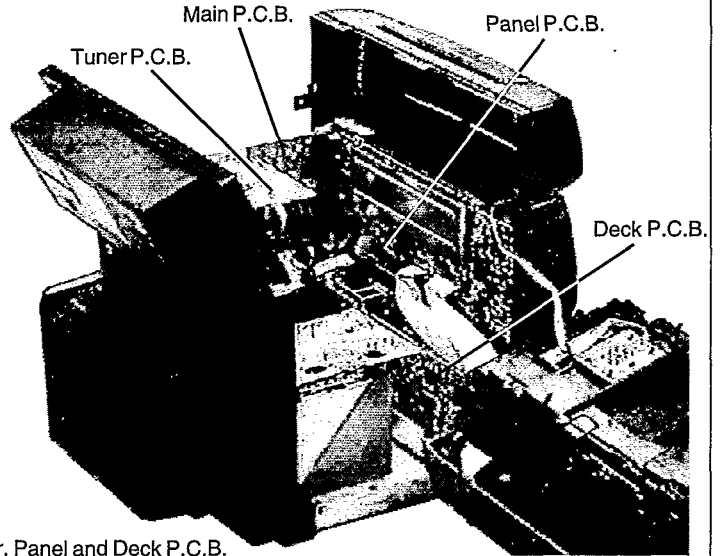

Step 3

Check the Main, Tuner, Panel and Deck P.C.B.

■ Main Component Replacement Procedures

1. Replacement of the Traverse Deck

Step 1 Follow the procedures in 'Disassembly of the Traverse Unit' (**Step 1** ~ **Step 2**).

Step 2

a X 2

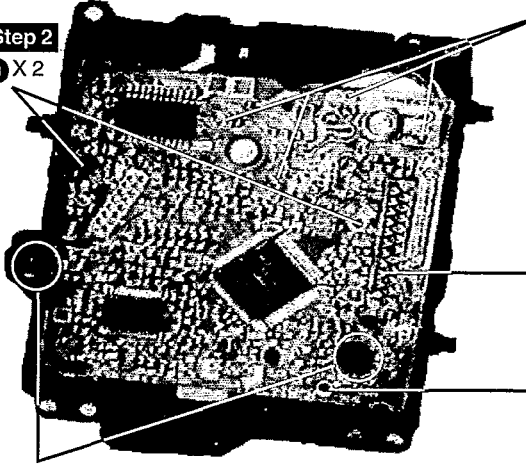

Step 4

Desolder the 4 legs of the 2 motors and pull out the Servo P.C.B.

Servo P.C.B.

Step 3

b X 1

Traverse Deck

Servo P.C.B.

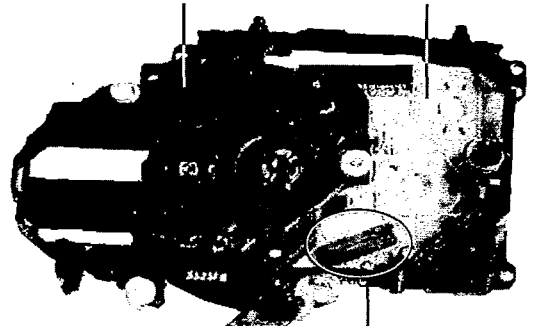

Step 6

Remove the flexible cable CN701.

Step 5

Widen the 2 bosses with a flat screwdriver and pull out the 2 pins. Then remove the Traverse Deck.

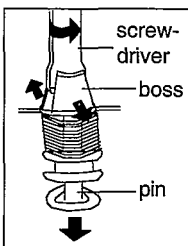

Note :
Insert a short pin into the flexible cable for traverse unit.

• Removal of the flexible cable
Push the top of the connector in the direction of the arrow ①, and then pull out the flexible cable in the direction of the arrow ②.

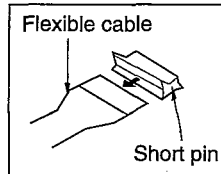
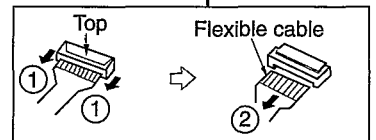

a



[XTV2+6G] (Brass)

b



[XTN2+6G] (Brass)

2. Replacement of the Power Amplifier IC and Regulator Transistors.

Step 1 Follow the procedures in 'Checking of the Main, Tuner, Panel and Deck P.C.B.' and remove the Front Panel.

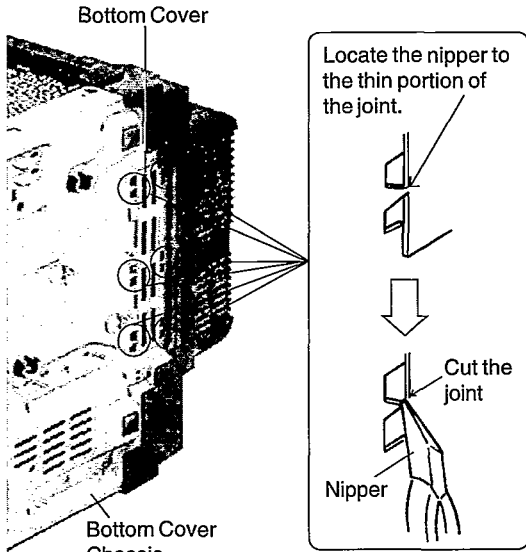

Step 2

Cut the joints (6 portion) between bottom cover and bottom cover chassis ass'y with a nipper.

Step 3

After cutting the joints (6 portions), bend the portions of the bottom chassis ass'y in the direction of arrow (a) with pliers. (Step 2 must be performed to avoid injury by sharp edge.)

Step 4

Unsolder the terminals of Power IC or Regulator Transistors on the solder surface.

Step 5

Remove 3 screws fixed to the Power IC and Transistor Holder, then remove Power IC, Transistor Holder and Regulator Transistors.

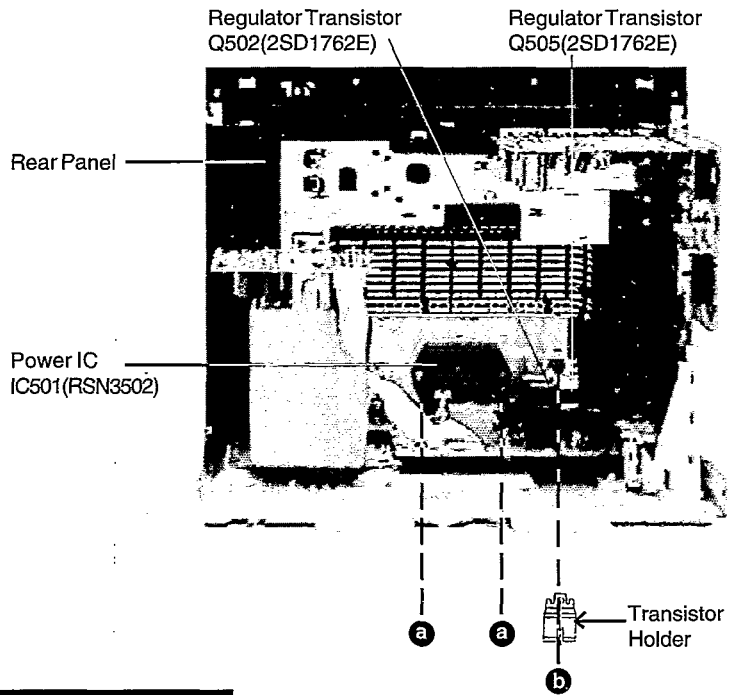
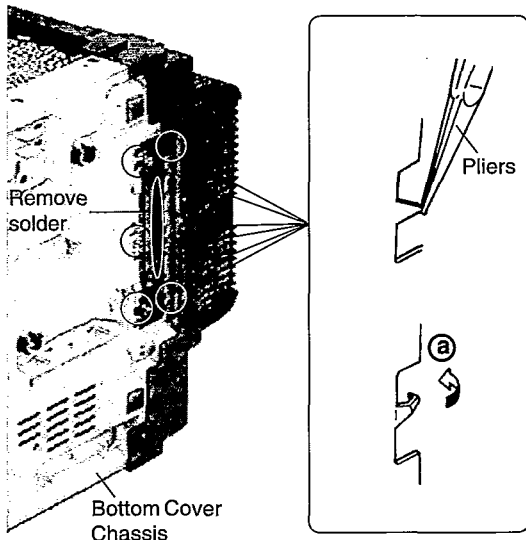

Assembly of Bottom Cover

After replacing the Power IC or Regulator Transistor, upset the bottom cover and align the ribs of bottom cover to the lugs on the bottom chassis ass'y. After mounting the bottom cover on the bottom chassis ass'y, fix it with a screw.

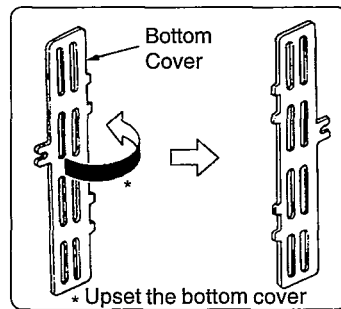
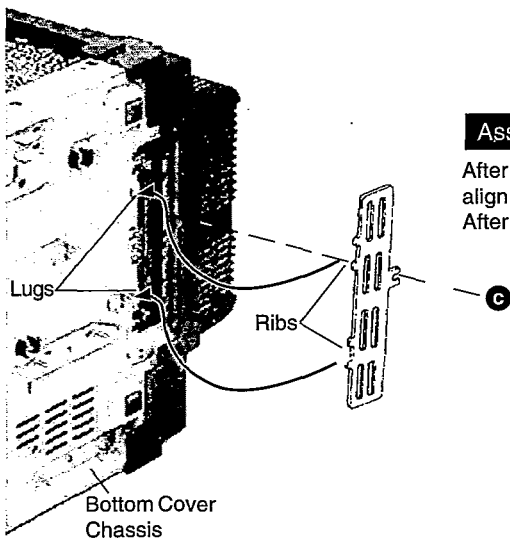

| | |
|--------------|--|
| a | |
| [XTW3+15T] | |
| b | |
| [XTB3+10JFZ] | |
| c | |
| [XTB3+8J] | |

■ Self-Diagnostic Display Function

■ Self-diagnostic display

This unit is equipped with a self-diagnostic display function which, if a problem occurs, will display an error code corresponding to the problem. Use this function when performing maintenance on the unit.

■ How to enter the Self-Diagnostic Function

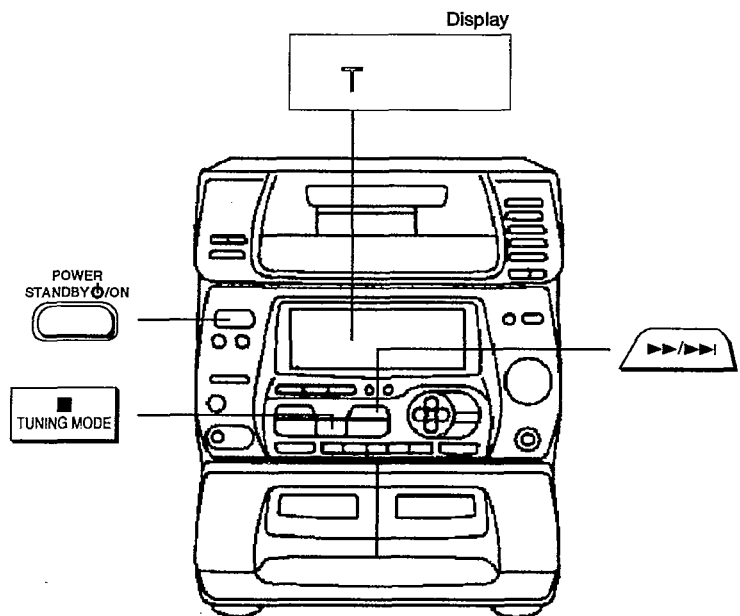
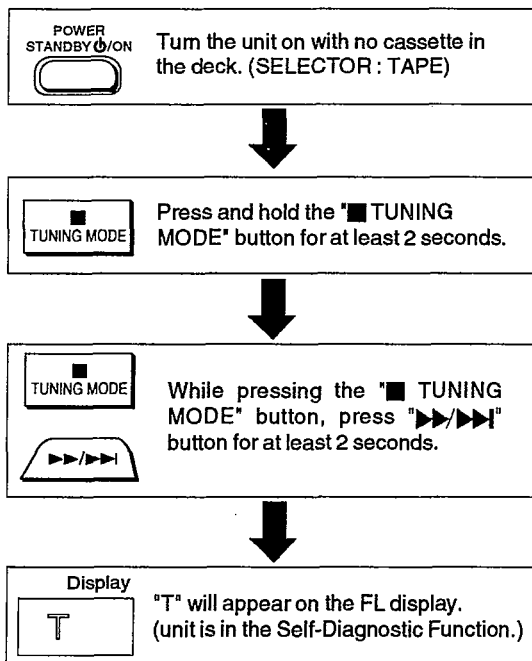

■ Cassette Mechanism Test (For error code H01, H02, H03, F01, F02)

1. Press "TAPE, DECK 1/2" to select Deck 2.
2. Load a cassette tape with the erasure prevention tab, remove from left side only and close the cassette holder.
3. Press "▶▶▶▶" (Tape will be stop after 2 seconds).
4. Load a cassette tape with the erasure prevention tab, remove from right side only and close the cassette holder.
5. Press "◀◀◀◀" (Tape will be stop after 2 seconds).
6. Load a pre-recorded tape with both side and close the cassette holder.
7. Press "▶ FM MODE/BP" (After TPS function, tape will stop automatically).
8. Press "REC START/STOP" (Tape will not move).
9. Press "■ TUNING MODE" to indicate Error code.
 - If several problem exist, error code will change each time when "■ TUNING MODE" is pressed. (e.g. H01 → H03 → F01 etc.)
10. Press "TAPE, DECK 1/2" to select Deck 1.
11. Repeat step 2 to 9 to test Deck 1. (Tape Deck 1 will not check H02 because of no recording function)

■ CD Mechanism Test (F15, F16, F25 ~ F28, F75)

1. Press "CD".
2. Press "CHECK -NEXT/-AUTO".
3. Press "■ TUNING MODE" to indicate Error Code.
 - If several problem exist, error code will change each time when "■ TUNING MODE" is pressed. (e.g. F15 → F16 → F25 etc.)

■ To clear all Error code

1. Press "■ TUNING MODE" button for 5 seconds.
2. FL indicator shows "CLEAR" for 1 second and change to "T".

■ How to get out from Self-Diagnostic function

1. Press "POWER" button OFF.

■ Power Amplifier Failure (F61)

1. When power amplifier fail, F61 will indicate automatically.

■ Description of Error Code

(1) Error detection for Cassette Mechanism block

| No. | Error | Error Display | Problem condition |
|-----|----------------------------|---------------|---|
| 1 | MODE SW detection error | H01 | Faulty operation of cassette mechanism. Faulty contact or short-circuit of mechanism mode switch (S951, S971). |
| 2 | REC INH SW detection error | H02 | Recording not possible. Faulty contact or short-circuit of REC INH switch (S974, S975). |
| 3 | HALF SW detection error | H03 | Playback can not perform. Faulty contact or short-circuit of HALF switch (S952, S972). |
| 4 | Reel Pulse detection error | F01 | The tape advances slightly and then stops. Faulty reel pulse, faulty hole detect IC (IC951, IC971). |
| 5 | TPS abnormal | F02 | Cassette deck will not perform TPS function. Faulty playback EQ/recording amplifier IC (IC101). |

(2) Error detection for CD/Changer block

| No. | Error | Error Display | Problem condition |
|-----|---|---------------|---|
| 1 | REST SW detection error | F15 | CD does not function. This error occurs when the Optical Pick Up REST SW (S701) is not detected within the specified time (about 8 seconds) |
| 2 | S3 (TUP) detection error | F16 | CD does not function. This error occurs when S3 (Traverse up detection) is not ON or OFF within the specified time. |
| 3 | S4 (DRO) detection error | F25 | Tray does not stay open. This error occurs when S4 (Tray open detection) is not ON or OFF during OPEN/CLOSE operation within the specified time. |
| 4 | Transmission error between CD servo LSI and micon | F26 | CD does not function. This error occurs when the POWER is ON for the CD block and an error is detected after the transmission has started. |
| 5 | S5 (TNO) detection error | F27 | Tray number does not detect correctly. This error occurs when S5 (Tray number detection) can not be detected normally or when the TRAY No. is uncertain. |
| 6 | S1 (STK), S2 (PLY) detection error | F28 | CD loading mechanism does not move correctly. This error occurs when S1 (stocker position detection) is not ON or OFF, or S2 (play position detection) is not ON or OFF within the specified time. |
| 7 | CD power error | F75 | CD does not function. Check if CDRST is H for SELECTOR at CD. If it is not H after 1 second, it shall be memorised as an error. (IC702) |

(3) Power Supply related error detection

| No. | Error | Error Display | Problem condition |
|-----|---------------------------|---------------|--|
| 1 | POWER AMP output abnormal | F61 | When POWER is switched on, power become off automatically. During normal operation, if DC DET become L, PCNT shall become L and the error display on the left shall be displayed. (IC501) |

■ CD Test Mode Function

This CD test mode is provided to check CD unit without connecting to changer loading mechanism. This mode shall operate CD PLAY with CD unit being connected only and CD Automatic Alignment result is shown on FL display.

■ How to set CD test mode

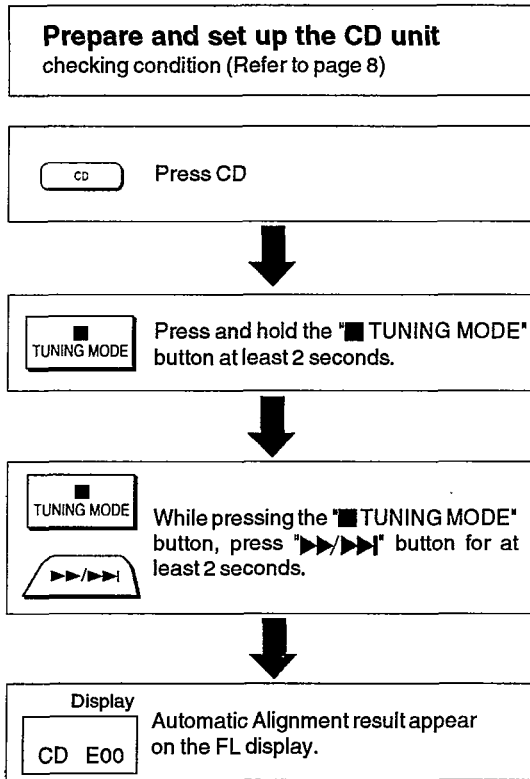

■ CD Automatic Alignment result indication

This function provided indication of error code as the result of Automatic Alignment of CD (Tracking, Focus, Offset, etc.). Based on these error codes, the faulty area can be located.

■ Error code Explanation

- The unit is satisfactory if the error code is E00
- Before testing, make sure that the test disc is free of scratches, dirt and that the optical pick up lens is clean.

| Error code | E00 | E01 | E02 | E03 | E04 | E05 | E06 | E07 | E08 | E09 | E0A | E0B | E0C | E0D | E0E | E0F |
|-------------------------------|-----|-----|-----|-----|-----|-----|-----|-----|-----|-----|-----|-----|-----|-----|-----|-----|
| Focus offset | ○ | ※ | ○ | ○ | ○ | ○ | ○ | ○ | ○ | ○ | ○ | ○ | ○ | ○ | ○ | ○ |
| Tracking offset | ○ | ※ | ○ | ○ | ○ | ○ | ○ | ○ | ○ | ○ | ○ | ○ | ○ | ○ | ○ | ○ |
| Focus Gain (Rough) | ○ | ※ | ○ | ○ | ○ | ○ | ○ | ○ | ○ | ○ | ○ | ○ | ○ | ○ | ○ | ○ |
| Tracking Gain (Rough) | ○ | - | ○ | × | ○ | × | ○ | × | ○ | × | ○ | × | ○ | × | ○ | × |
| Tracking balance | ○ | - | × | × | ○ | ○ | × | × | ○ | ○ | × | × | ○ | ○ | × | × |
| Focus balance | ○ | - | ○ | ○ | × | × | × | × | ○ | ○ | ○ | ○ | × | × | × | × |
| Tracking or Focus Gain (Fine) | ○ | - | ○ | ○ | ○ | ○ | ○ | ○ | × | × | × | × | × | × | × | × |

○ Satisfy

× Fault

(※ Fault either items)

■ Reliability test mode for CD / CD CHANGER

This function provided to check CD player and CD CHANGER mechanism. Use this function to check CD player and loading mechanism operation after repair or to find intermittent problem.

■ How to set reliability test mode.

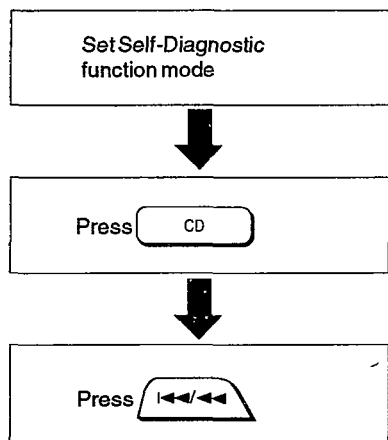

■ Operation and function

In the reliability test mode, the set repeat the following operation:

- 1) Open tray 1;
- 2) Fully OPEN condition, CLOSE 1 sec after drawer stops;
- 3) PLAY the first track of disc 1 for 2 sec;
- 4) Skip to the last track, play for 2 sec and stop;
- 5) Open tray 3;
- 6) Fully OPEN condition, CLOSE 1 sec after drawer stops;
- 7) PLAY the first track of the disc 3 for 2 sec;
- 8) Open tray 5;
- 9) Fully OPEN condition, CLOSE 1 sec after drawer stops;
- 10) Return to above step 1) after 1 sec.

- During this series of operation, the number of its operation shall be shown in the alphanumeric display repeatedly.

It shall start from

- It shall move up one counter when step 1- 10 of the above operations end.

It shall display after has been reached.

- During operation, if TNO SW and tray number detected are different, this error is counted and shown at the upper 2 digits of display. (e.g. Tray 3 pulse could not detected even when tray 3 is operating).

-

- Execute POWER OFF to cancel the reliability test mode and the self-diagnostic mode.

Measurements and Adjustments

< TUNER SECTION >

• LW ALLOCATION SETTING

By adjusting the allocation, you can enable this tuner to receive LW broadcasts allocated in 1 kHz steps.

1. Press and hold TUNER, BAND for approximately 5 seconds. The frequency display will be returned to the minimum frequency of the LW band and the display will begin to flash. Keep holding for approximately 5 more seconds.
2. When the display stops flashing, release TUNER, BAND. To return to the original frequency, repeat step 1 to 2.

Note

After changing the allocation setting, the frequencies you previously preset to the memory will be cleared.

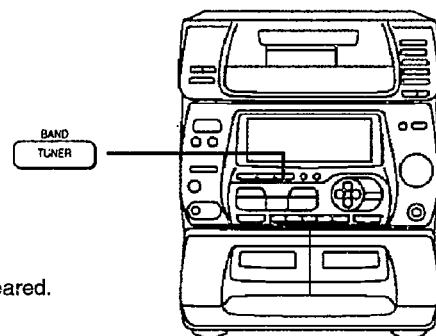

< CASSETTE DECK SECTION >

• Measurement Condition

- Reverse-mode selector switch :
- Tape edit : NORMAL
- Record timer : OFF
- Dolby NR : OFF
- Make sure head, capstan and pressure roller are clean.
- Judgeable room temperature $20 \pm 5^\circ\text{C}$ ($68 \pm 9^\circ\text{F}$)

• Measuring instrument

- EVM (Electronic Voltmeter)
- Digital frequency counter

• Test tape

- Head azimuth adjustment (8 kHz, -20 dB); QZZCFM
- Tape speed adjustment (3 kHz, -10 dB); QZZCWAT
- Playback gain adjustment (315 Hz, 0 dB); QZZCFM
- Normal reference blank tape; QZZCRA
- CrO₂ tape; QZZCRX

• Head Azimuth Adjustment (Deck 1/2)

Caution :

- Please replace both azimuth adjustment screws (RHE5152ZB) and springs (RMB0331) simultaneously when readjusting the head azimuth. (shown in Fig. 2)

Even if you wish to readjust the head azimuth without replacing the screws and springs, a fine adjustment cannot be done because of the screw-locking bond adhered to the azimuth screw and spring.

- Please remove the screw-locking bond left on the head base when replacing the azimuth screw.
- If you wish to readjust the head azimuth, be sure to adjust with adhering the cassette tape closely to the mechanism by pushing the center of cassette tape with your finger. (shown in Fig. 3)

1. Playback the azimuth adjustment portion (8 kHz, -20 dB) of the test tape (QZZCFM) in the forward play mode. Vary the azimuth adjusting screw until the output of the R-CH (PB OUT-R) are maximized.
2. Perform the same adjustment in the reverse play mode.
3. After the adjustment, apply screwlock to the azimuth adjusting screw.

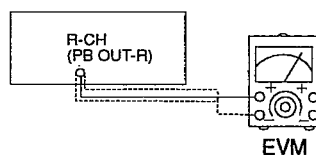

Fig. 1

- (RHE5152ZB)
- (RMB0331)

Fig. 2

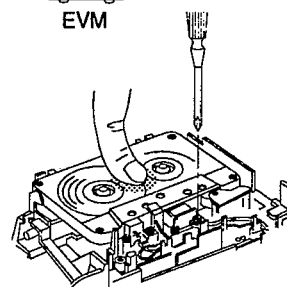

Fig. 3

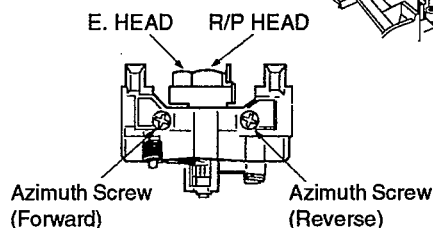

Fig. 4

• Tape Speed Adjustment (Deck 1/2)

1. Set the tape edit button to "NORMAL" position.
2. Insert the test tape (QZZCWAT) to DECK 2 and playback (FWD side) the middle portion of it.
3. Adjust VR201 (DECK 2) for the output value shown below.

Adjustment target : 2980 ~ 3020 Hz (NORMAL speed)

4. After alignment, assure that the output frequency of the DECK 2 REV and DECK 1 FWD/REV are within ± 60 Hz of the value of the output frequency of DECK 2 FWD.
5. Set the tape edit button to "HIGH" position.
6. Short-circuit between TP200 and TP10.
7. Assure that the output from DECK 1/2 are within the standard value.

Standard value : 5000 \pm 210 Hz (HIGH speed)

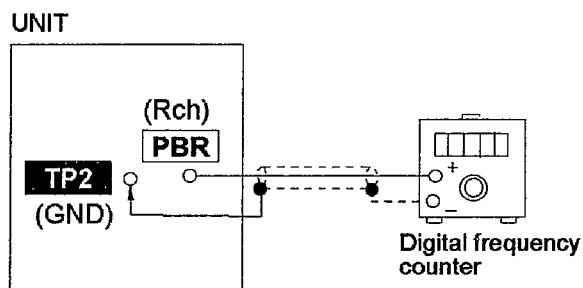

• Bias and Erase Voltage Check

1. Set the unit to "AUX" position.
2. Insert the Normal blank tape (QZZCRA) into DECK 2 and set the unit to "REC" mode (use "REC START/STOP" key).
3. Measure and make sure that the output is within the standard value.
4. Insert the CrO₂ tape (QZZCRX).
5. Repeat steps 2 and 3.

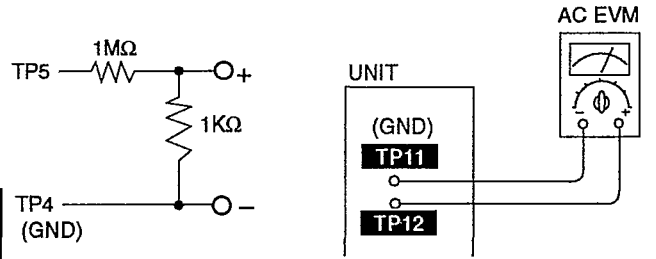

Bias voltage for Deck 2 (Standard value): 19 ± 4mV (Normal)
 27 ± 5mV (CrO₂)
Erase voltage for Deck 2 (Standard value): more than 100mV (Normal)
 more than 150mV (CrO₂)

• Bias Frequency Adjustment (Deck 2)

1. Set the unit to "AUX" position.
2. Insert the Normal blank tape (QZZCRA) into DECK2 and set the unit to "REC" mode (use "REC START/STOP" key).
3. Adjust L201 so that the output frequency is within the standard value.

Standard Value : 98 ± 8 kHz

• Alignment Points

<Cassette Deck Section>

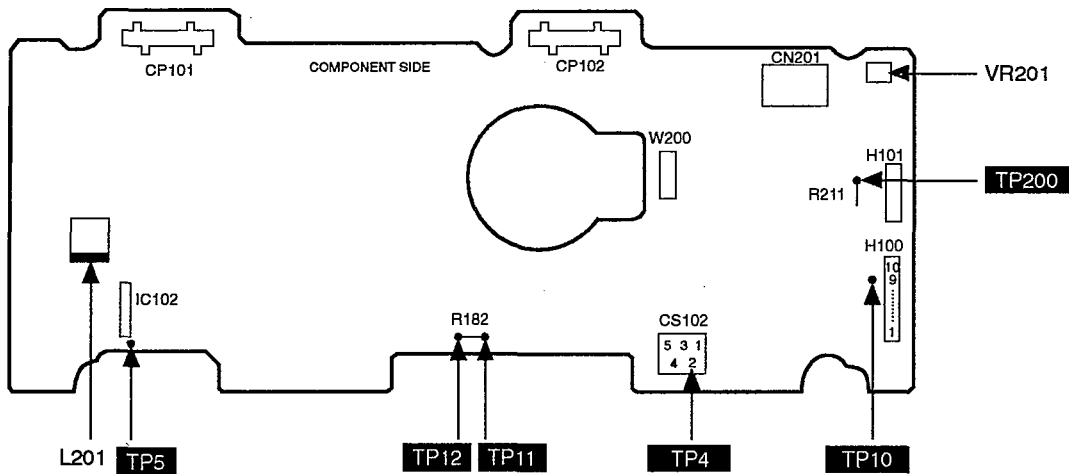

■ Terminal Function of ICs

• IC701 (AN8835SBE1) Servo Amplifier

| Pin No. | Mark | I/O | Function |
|---------|-------|-----|--|
| 1 | PDA | I | PD signal input |
| 2 | PDB | I | PD signal input |
| 3 | VCC | I | Power supply connection |
| 4 | LPD | I | Laser PD connection |
| 5 | LD | O | Power out for LD driving |
| 6 | RF | O | RF signal output |
| 7 | RFIN | I | RF signal input |
| 8 | CAGC | I | AGC loop filter connection |
| 9 | ARF | O | RF-AGC output |
| 10 | CSBRT | I | Capacitor for detection connection |
| 11 | CEA | I | Capacitor connection for HPF amplifier |
| 12 | BDO | O | BDO output ("H" : drop out) |
| 13 | LDON | I | LD APC input ("H" : ON, "L" : OFF) |
| 14 | GND | — | Ground connection |

| Pin No. | Mark | I/O | Function |
|---------|--------|-----|--|
| 15 | /RFDET | O | NRFDET output ("L" : detection) |
| 16 | CROSS | O | CROSS output (Track cross signal output) |
| 17 | OFTR | O | Off-track output ("L" : ON track, "H" : OFF track) |
| 18 | VDET | O | VDET output ("H" : Vibration detected) |
| 19 | ENV | O | RF envelope detection |
| 20 | TEBPF | I | Vibration detection signal input |
| 21 | CCRS | I | Capacitor for LPF connection |
| 22 | TE | O | Tracking error signal output |
| 23 | FE | O | Focus error signal output |
| 24 | TBAL | I | Tracking balance signal input |
| 25 | FBAL | I | Focus balance signal input |
| 26 | VREF | O | Reference voltage output |
| 27 | PDE | I | PD signal input |
| 28 | PDF | I | PD signal input |

• IC703 (AN8389SE1) Focus coil / Tracking coil / Traverse motor / Spindle motor driver

| Pin No. | Mark | I/O | Function |
|---------|--------|-----|--|
| 1 | VCC | I | Power supply terminal |
| 2 | VREF | I | Reference voltage input |
| 3 | IN4 | I | Motor driver (4) input |
| 4 | IN3 | I | Motor driver (3) input |
| 5 | GND | — | Ground connection |
| 6 | NC | — | Ground connection |
| 7 | NRESET | I | Reset input |
| 8 | GND | — | Ground connection |
| 9 | IN2 | I | Motor driver (2) input |
| 10 | PC2 | I | PC2 (power cut) input |
| 11 | IN1 | I | Motor driver (1) input |
| 12 | PC1 | I | PC1 (power cut) input (Not used, open) |

| Pin No. | Mark | I/O | Function |
|---------|-------|-----|--|
| 13 | PVCC1 | I | Power supply (1) for driver |
| 14 | PGND1 | — | Ground connection (1) for driver |
| 15 | D1- | O | Motor driver (1) reverse-action output |
| 16 | D1+ | O | Motor driver (1) forward-action output |
| 17 | D2- | O | Motor driver (2) reverse-action output |
| 18 | D2+ | O | Motor driver (2) forward-action output |
| 19 | D3- | O | Motor driver (3) reverse-action output |
| 20 | D3+ | O | Motor driver (3) forward-action output |
| 21 | D4- | O | Motor driver (4) reverse-action output |
| 22 | D4+ | O | Motor driver (4) forward-action output |
| 23 | PGND2 | — | Ground connection (2) for driver |
| 24 | PVCC2 | I | Power supply (2) for driver |

• IC702 (MN662741RPA) Servo processor / Digital signal processor / Digital filter / D/A converter

| Pin No. | Mark | I/O | Function |
|---------|--------|-----|--|
| 1 | BCLK | O | Serial bit clock terminal (Not used, open) |
| 2 | LRCK | O | L/R discriminating signal (Not used, open) |
| 3 | SRDATA | O | Serial data (Not used, open) |
| 4 | DVDD1 | I | Power supply (digital circuit) terminal |
| 5 | DVSS1 | — | GND (digital circuit) terminal |
| 6 | TX | O | Digital audio interface signal |
| 7 | MCLK | I | Microprocessor command clock signal |
| 8 | MDATA | I | Microprocessor command data signal |
| 9 | MLD | I | Microprocessor command load signal |
| 10 | SENSE | O | Sense signal output (OFT, FESL, MAGEND, NAJEND, POSAD, SFG) |
| 11 | /FLOCK | O | Optical servo condition (focus) ("L" : lead-in) |
| 12 | /TLOCK | O | Optical servo condition (tracking) ("L" : lead-in) |
| 13 | BLKCK | O | Sub-code block clock (f=75Hz) |
| 14 | SQCK | I | External clock signal input for sub-code Q register. |
| 15 | SUBQ | O | Sub-code Q code output |
| 16 | DMUTE | I | Muting input ("H" : mute) |
| 17 | STAT | O | Status signal output (CRC, CUE, CLVS, TTSTVP, FCLV, SQCK) |
| 18 | /RST | I | Reset input |
| 19 | SMCK | O | 1/2-divided clock signal of crystal oscillating at MSEL = "H" (fSMCK=8.4672MHz) 1/4-divided clock signal of crystal oscillating at MSEL = "L" (fSMCK=4.2336MHz) |
| 20 | PMCK | O | 1/192-divided clock signal of crystal oscillating (fPMCK=88.2kHz) (Not used, open) |
| 21 | TRV | O | Traverse servo control output |
| 22 | TVD | O | Traverse drive signal output |
| 23 | PC | O | Spindle motor ON signal output ("L" : ON) |
| 24 | ECM | O | Spindle motor drive signal output (forced mode output) |
| 25 | ECS | O | Spindle motor drive signal output (servo error signal output) |
| 26 | KICK | O | Kick pulse output |
| 27 | TRD | O | Tracking drive output |
| 28 | FOD | O | Focus drive output |
| 29 | VREF | I | D/A (drive) output (TVD, ECS, TRD, FOD, FBAL, TBAL) Reference voltage input. |
| 30 | FBAL | O | Focus balance adjustment output (Not used, open) |
| 31 | TBAL | O | Tracking balance adjustment output |
| 32 | FE | I | Focus error signal input (analog input) |
| 33 | TE | I | Tracking error signal input (analog input) |
| 34 | RFENV | I | RF envelope signal input |
| 35 | VDET | I | Vibration detection signal input ("H" : detection) |

| Pin No. | Mark | I/O | Function |
|---------|--------|-----|---|
| 36 | OFT | I | Off-track signal input ("H" : off track) |
| 37 | TRCRS | I | Track cross signal input |
| 38 | /RFDET | I | RF detection signal input ("L" : detection) |
| 39 | BDO | I | Dropout signal input ("H" : Dropout) |
| 40 | LDON | O | Laser on signal output ("H" : ON) |
| 41 | TES | O | Tracking error shunt signal output ("H" : shunt) |
| 42 | PLAY | O | Play signal out ("H" : PLAY) |
| 43 | WVEL | O | Double speed status signal output ("H" : DS) |
| 44 | ARF | I | RF signal input |
| 45 | IREF | I | Reference current input |
| 46 | DRF | I | DSL bias (Not used, open) |
| 47 | DSLIF | I/O | DSL loop filter |
| 48 | PLLF | I/O | PLL loop filter |
| 49 | VCOF | I/O | VCO loop filter (Not used, open) |
| 50 | AVDD2 | I | Power supply input (for analog circuit) |
| 51 | AVSS2 | — | GND (for analog circuit) |
| 52 | EFM | O | EFM signal output (Not used, open) |
| 53 | PCK | O | PLL extraction clock output (Not used, open) (fPCK=4.321 MHz during normal playback) |
| 54 | PDO | O | Phase comparison signal of EFM and PCK signals (Not used, open) |
| 55 | SUBC | O | Sub-code serial data output (Not used, open) |
| 56 | SBCK | I | Sub-code frame clock signal output (fCLDCK=7.35kHz during normal playback) |
| 57 | VSS | — | GND |
| 58 | X1 | I | Crystal oscillating circuit input (f=16.9344MHz) |
| 59 | X2 | O | Crystal oscillating circuit output (f=16.9344MHz) |
| 60 | VDD | I | Power supply input (for oscillating circuit) |
| 61 | BYTCK | O | Byte clock output (Not used, open) |
| 62 | /CLDCK | O | Clock input for sub-code serial data (Not used, open) |
| 63 | FCLK | O | Crystal frame clock signal output (fCLK=7.35kHz, double=14.7kHz) |
| 64 | PFLAG | O | Interpolation flag output ("H" : interpolation) (Not used, open) |
| 65 | FLAG | O | Flag output (Not used, open) |
| 66 | CLVS | O | Spindle servo phase synchronizing signal output (("H" : CLV, "L" : rough servo) (Not used, open) |
| 67 | CRC | O | Sub-code CRC checked output (("H" : OK, "L" : NG) (Not used, open) |
| 68 | DEMPH | O | De-emphasis ON signal output (("H" : ON) (Not used, open) |
| 69 | RESY | O | Frame resynchronizing signal output (Not used, open) |
| 70 | /RST2 | I | Reset input through MASH circuit ("L" : Reset) |
| 71 | /TEST | I | Test input |

| Pin No. | Mark | I/O | Function |
|---------|-------|-----|---|
| 72 | AVDD1 | I | Power supply input (for analog circuit) |
| 73 | OUTL | O | Left channel audio signal output |
| 74 | AVSS1 | — | GND |
| 75 | OUTR | O | Right channel audio signal output |
| 76 | RSEL | I | RF signal polarity assignment input (at "H" level, RSEL="H", at "L" level, RSEL="L") |
| 77 | CSEL | I | Crystal oscillating frequency designation input |

| Pin No. | Mark | I/O | Function |
|---------|------|-----|--|
| | | | "L" : 16.9344MHz "H" : 33.8688MHz |
| 78 | PSEL | I | Test input (normally "L") (Not used, open) |
| 79 | MSEL | I | Output mode switching of SUBQ terminal ("H" : Q code buffer mode) |
| 80 | SSEL | I | Output frequency switching for SMCK terminal "H" : SMCK=8.4672MHz "L" : MCK=4.2336MHz (Not used, open) |

• IC601 (M38197MA136F) System Microprocessor

| Pin No. | Mark | I/O | Function |
|---------|-------------------|-----|---|
| 1 | DECK 2 | I | Mecha condition input(PLAY, FF/RW, MOTOR) |
| 2 | DECK 1 | I | Mecha condition input(PLAY, FF/RW, MOTOR) |
| 3 | TPS | I | TPS input |
| 4 | CRT | — | CR timer |
| 5 | KEY 4 | I | Key 4 input |
| 6 | KEY 3 | I | Key 3 input |
| 7 | KEY 2 | I | Key 2 input |
| 8 | KEY 1 | I | Key 1 input |
| 9 | SER 1 | O | LED drive clock output |
| 10 | VOL OUT | O | Volume control DA output |
| 11 | SER 2 | O | LED drive data output |
| 12 | SER 3 | O | LED drive data output |
| 13 | SER 4 | O | Key control clock output |
| 14 | SER 5 | O | Key control strobe output |
| 15 | SPEANA INPUT | I | Spectrum analyser input |
| 16 | CHG SW1 | I | CD changer SW input (STK_SW, TUP_SW) |
| 17 | CHG SW2 | I | CD changer SW input (DR0_SW, PLY_SW, TNO_SW) |
| 18 | CDRST | I | CD reset input |
| 19 | STATUS | I | CD signal processor status input |
| 20 | SQCK | O | CD subcode clock output |
| 21 | NC | — | No connection |
| 22 | SUBQ | I | CD subcode data input |
| 23 | TLOCK | I | CD tracking lock input |
| 24 | FLOCK | I | CD focus lock input |
| 25 | SENSE | I | CD servo processor sense input |
| 26 | MLD/ PLLCE | O | CD command load output |
| 27 | MDATA/ PLLDATA | O | CD command data output |
| 28 | MCLK/ PLLCLK | O | CD command clock output |
| 29 | RESTSW | I | CD REST detect SW input |
| 30 | BLKCK | I | CD block clock input |



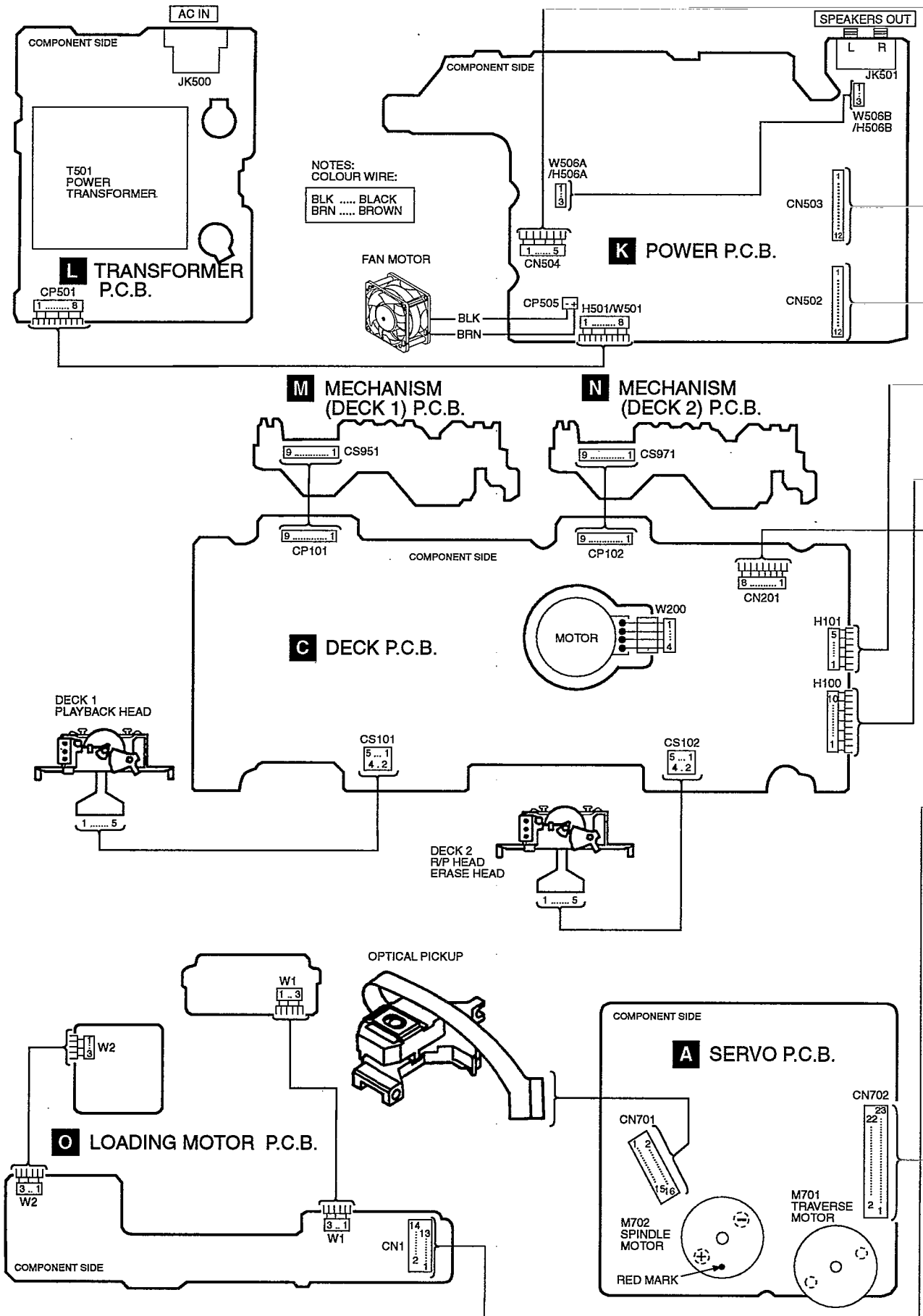

| Pin No. | Mark | I/O | Function |
|---------|-------------|-----|---|
| 31 | RMT | I | Remote control signal input |
| 32 | DCDET | I | DC detect input |
| 33 | P.CONT | O | Power control output |
| 34 | /HALT | I | AC failure detect input |
| 35 | /RESET | I | RESET input |
| 36 | XCIN | I | X'tal oscillator (f = 32.768 kHz sub clock) |
| 37 | XCOU | O | X'tal oscillator (f = 32.768 kHz sub clock) |
| 38 | XIN | I | X'tal oscillator (f = 6.0 MHz Main clock) |
| 39 | XOUT | O | X'tal oscillator (f = 6.0 MHz Main clock) |
| 40 | VSS | — | Ground (0V) |
| 41 | MBP1 | O | MPU beat proof output 1 |
| 42 | MBP2 | O | MPU beat proof output 2 |
| 43 | CDGMUTE | — | No connection |
| 44 | /CDGRESET | — | No connection |
| 45 | CD DMUTE | O | CD digital mute output |
| 46 | SPE CONT A | — | No connection |
| 47 | SPE CONT B | — | No connection |
| 48 | SPE CONT C | — | No connection |
| 49-52 | GRD16-GRD13 | — | No connection |
| 53 | GRD12 | O | FL digit (grid) drive signal output |
| 54-55 | GRD11-GRD10 | — | No connection |
| 56-64 | GRD9-GRD1 | O | FL digit (grid) drive signal output |
| 65-88 | AND1-AND24 | O | FL segment (anode) drive output |
| 89 | JOG A | I | Jog dial signal input A |
| 90 | JOG B | I | Jog dial signal input B |
| 91 | VCC | I | Power supply (+5V) |
| 92 | REGION IN | I | Area setting terminal |
| 93 | MKCLK | O | Cassette deck control clock signal output |
| 94 | MKDATA | O | Cassette deck control data output |
| 95 | SD IN | I | Tuner signal DET input |
| 96 | STEREO IN | I | Tuner stereo DET input |
| 97 | DO IN | I | Tuner PLL if data input |
| 98 | VP | I | Power input (-30V) |
| 99 | VSS | — | Ground (0V) |
| 100 | VREF | I | Reference for A-D |

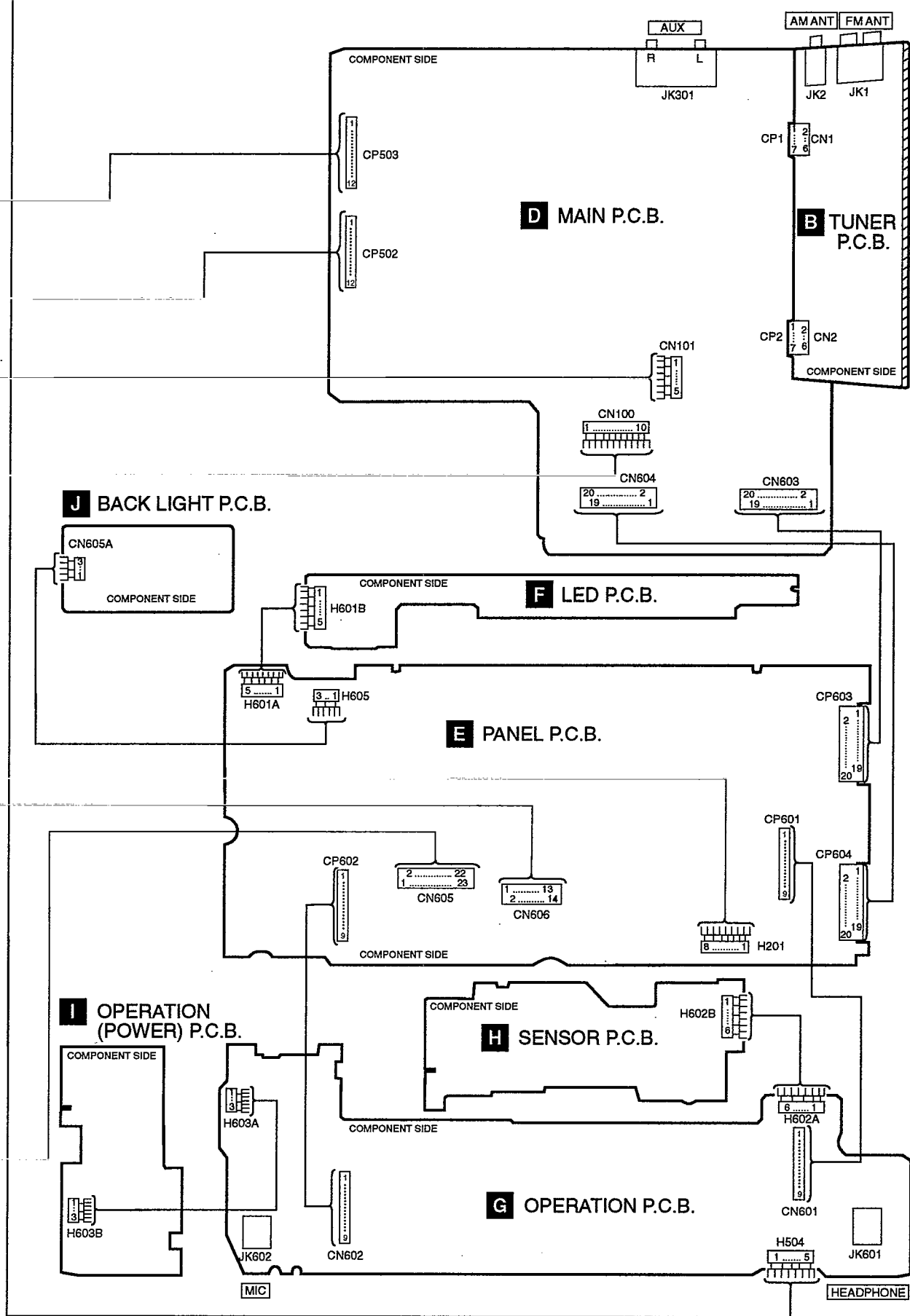
Wiring Connection Diagram



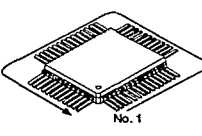
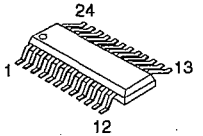
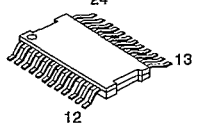
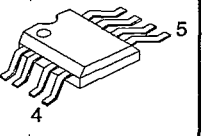
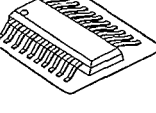
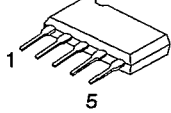
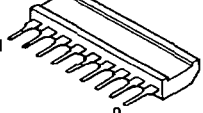
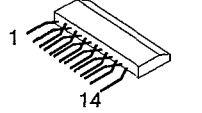

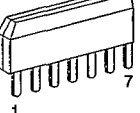
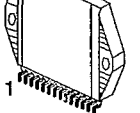
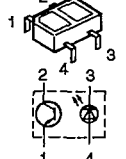
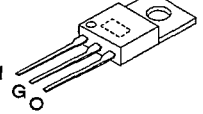
Terminal Guide of ICs, Transistors and Diodes

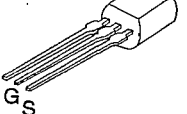
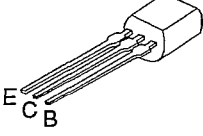
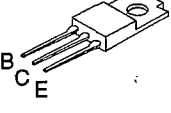
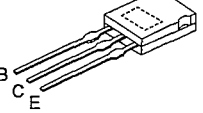
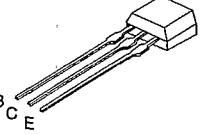
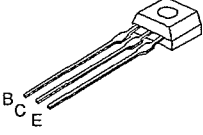
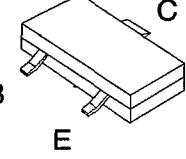
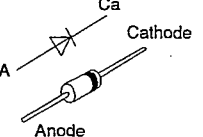
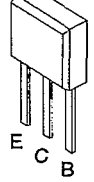
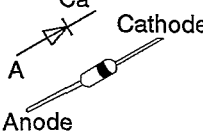
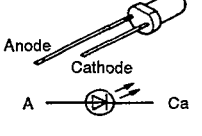
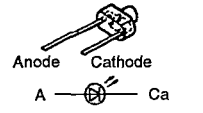
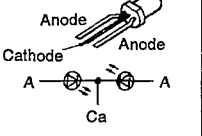
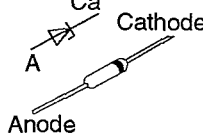
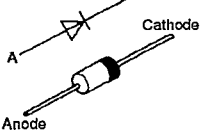
| | | | | | |
|---|--|--|--|---|--|
| <p>M38197MA136F(100P) MN662741RPA(80P)</p>  <p>No.1</p> | <p>LA1832A LC7218</p>  <p>24 13 12</p> | <p>AN8389SE1</p>  <p>24 13 12</p> | <p>BA4558FDXE2</p>  <p>8 5 4</p> | <p>AN8835SBE1 (28P) BU2040F-E2 (16P) BU2090F-E2 (16P) BU4052BCF-E2 (16P) BU4066BCF-E2 (14P) CXA1102M-T4 (16P) M51167BFP-E1 (36P) M62422FPE1 (42P)</p>  <p>No.1</p> | |
| <p>BA7755A</p>  <p>5</p> | <p>DAP803</p>  <p>9</p> | <p>M51131L-702</p>  <p>14</p> | <p>BA6418N</p>  <p>9</p> | <p>TA2011S</p>  <p>7</p> | <p>RSN3502</p>  <p>14</p> |
| <p>0N2180RLC</p>  <p>1 2 3 4</p> | <p>LM2940T5M</p>  <p>I G O</p> | <p>2SJ164QRTA</p>  <p>S G D</p> | <p>2SK301QTA</p>  <p>D G S</p> | <p>2SB621ARTA 2SB621RTA 2SC2001KTA 2SD1302STA 2SD965RTA</p>  <p>E C B</p> | |
| <p>2SB1185E 2SD1762E</p>  <p>B C E</p> | <p>2SD2037ETA</p>  <p>B C E</p> | <p>2SA933SSTA 2SC1740SLNET 2SC1740SSTA RVTDTA143XST</p>  <p>B C E</p> | | <p>2SC2785FETA 2SC2785FTA 2SC2787LTA 2SD1020HTA BA1A4ZTA BA1F4MTA BA1L3ZTA BN1L3NTA</p>  <p>B C E</p> | |
| <p>2SB709S</p>  <p>B C E</p> | <p>1D3E 1N5402BM21</p>  <p>A Ca Cathode Anode</p> | <p>2SC2784FTA 2SD1450STA BA1L4MTA BA1L4ZTA BN1A4MTA</p>  <p>E C B</p> | | <p>1SS254TA 1SS291TA MA165TA MA167TA MA700ATA RVD1SS133TA</p>  <p>A Ca Cathode Anode</p> | |
| <p>SLR325DCT31</p>  <p>Anode Cathode A Ca</p> | <p>SLR342DCTB7 SLR342MCTB7 SLR-325MC</p>  <p>Anode Cathode A Ca</p> | <p>SPR505MDTT</p>  <p>Anode Cathode A Ca</p> | <p>MTZJ11CTA MTZJ12BTA MTZJ13ATA MTZJ15BTA MTZJ15CTA MTZJ20BTA MTZJ33CTA MTZJ3R6BTA</p> <p>MTZJ4R7BTA MTZJ5R1CTA MTZJ5R6BTA MTZJ6R8BTA MTZJ6R8CTA MTZJ7R5CTA MTZJ8R2BTA MTZJ9R1ATA</p>  <p>A Ca Cathode Anode</p> | | |
| <p>RL1N4003N02</p>  <p>A Ca Cathode Anode</p> | | | | | |

Block Diagram

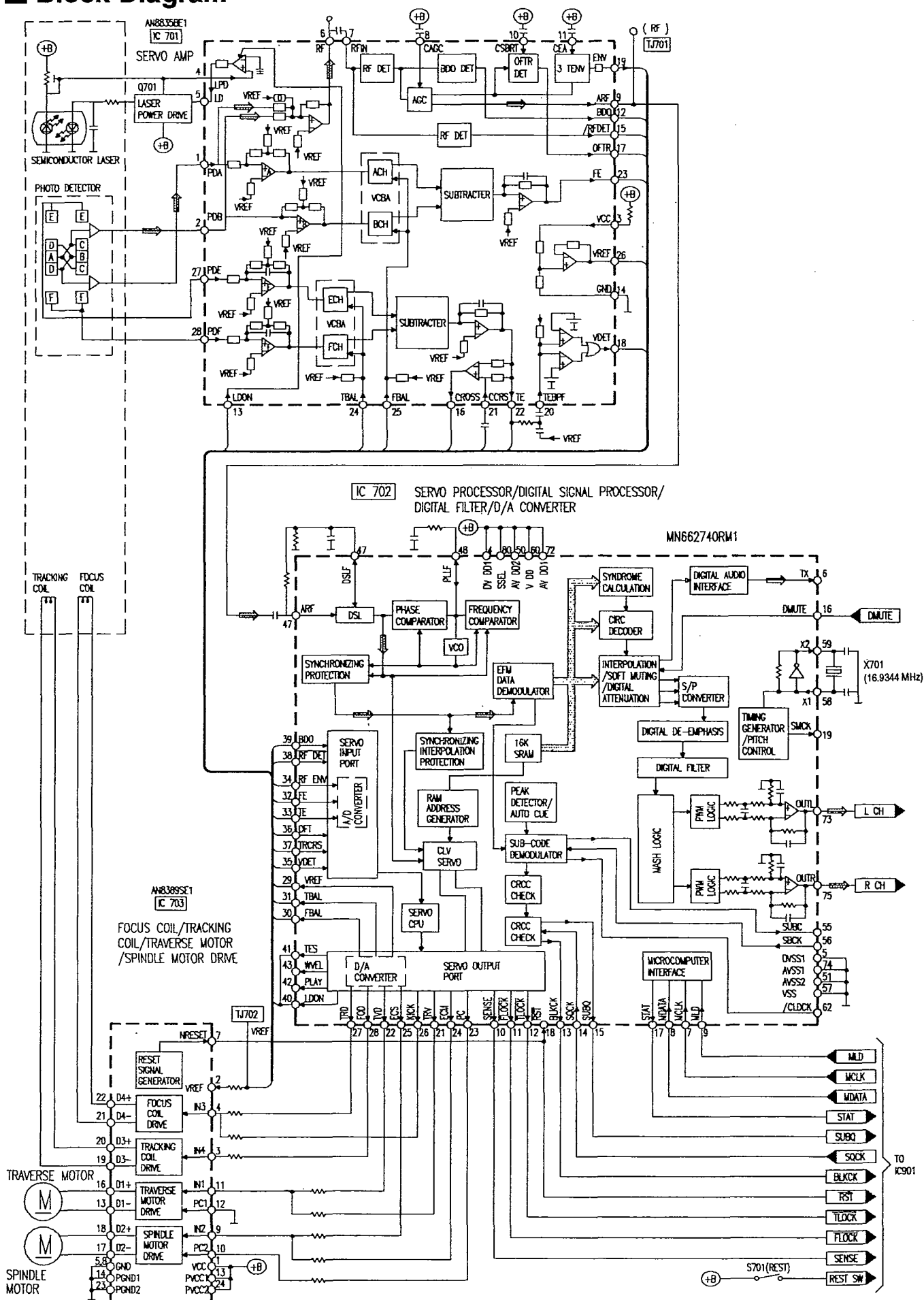

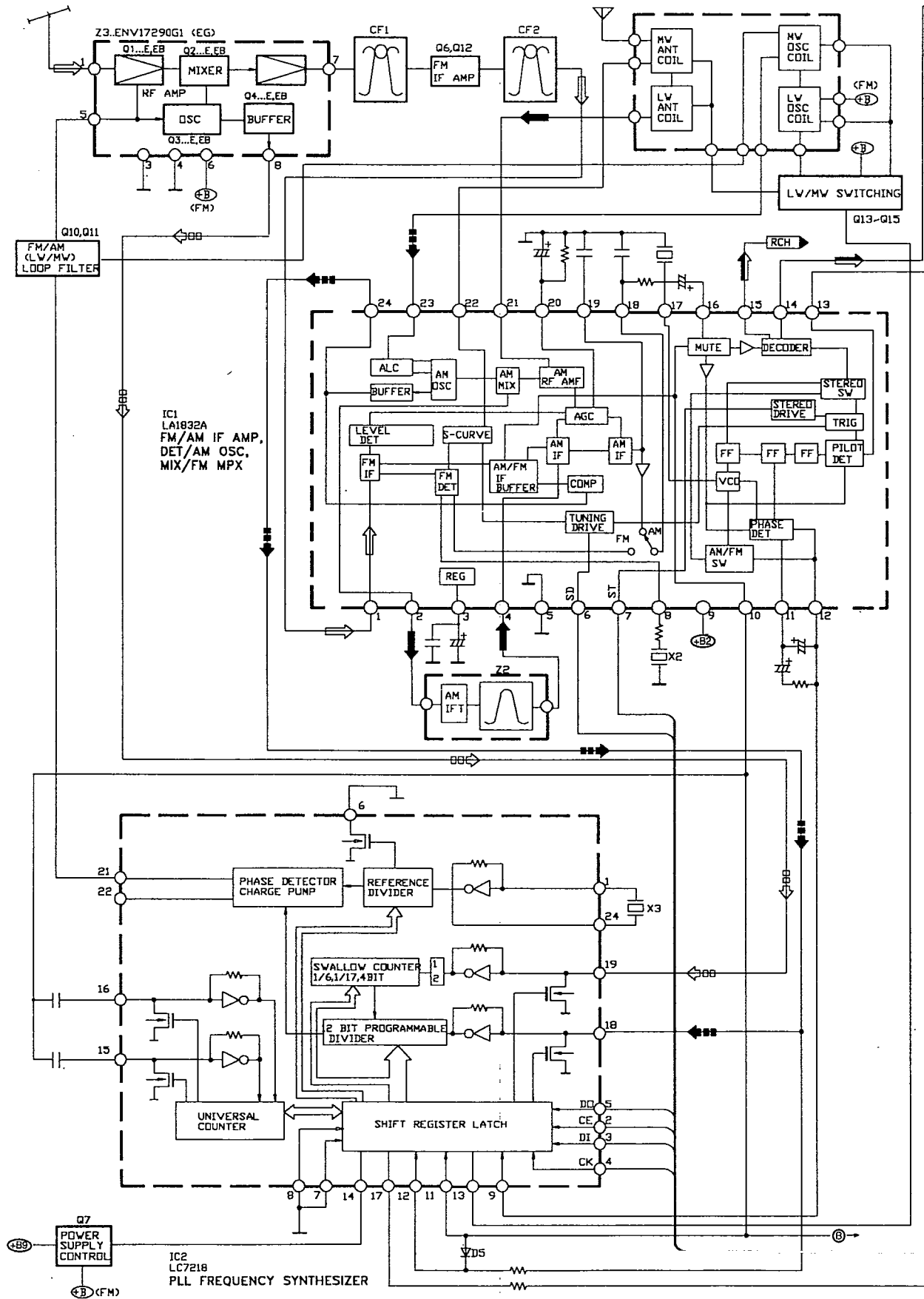

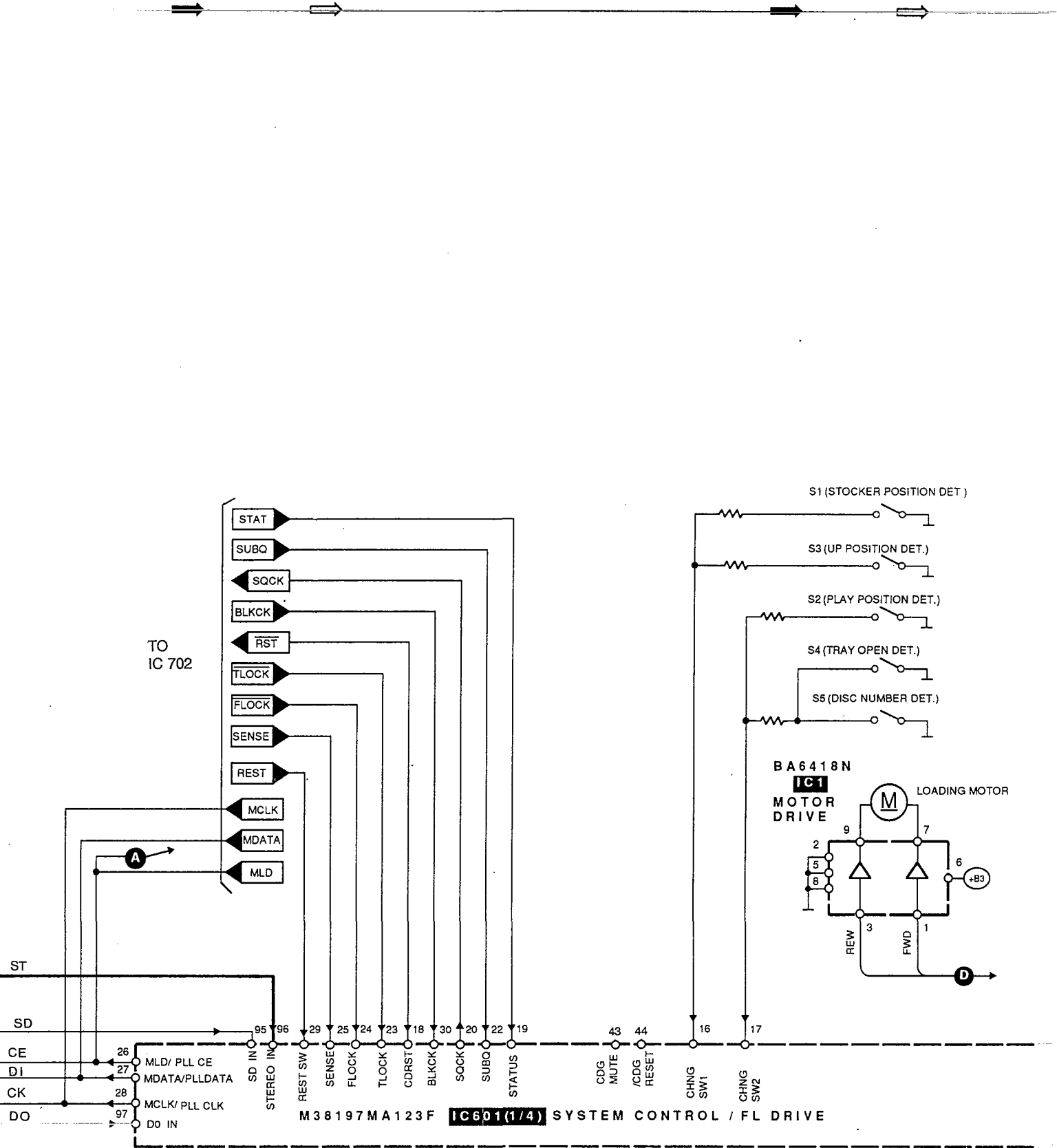

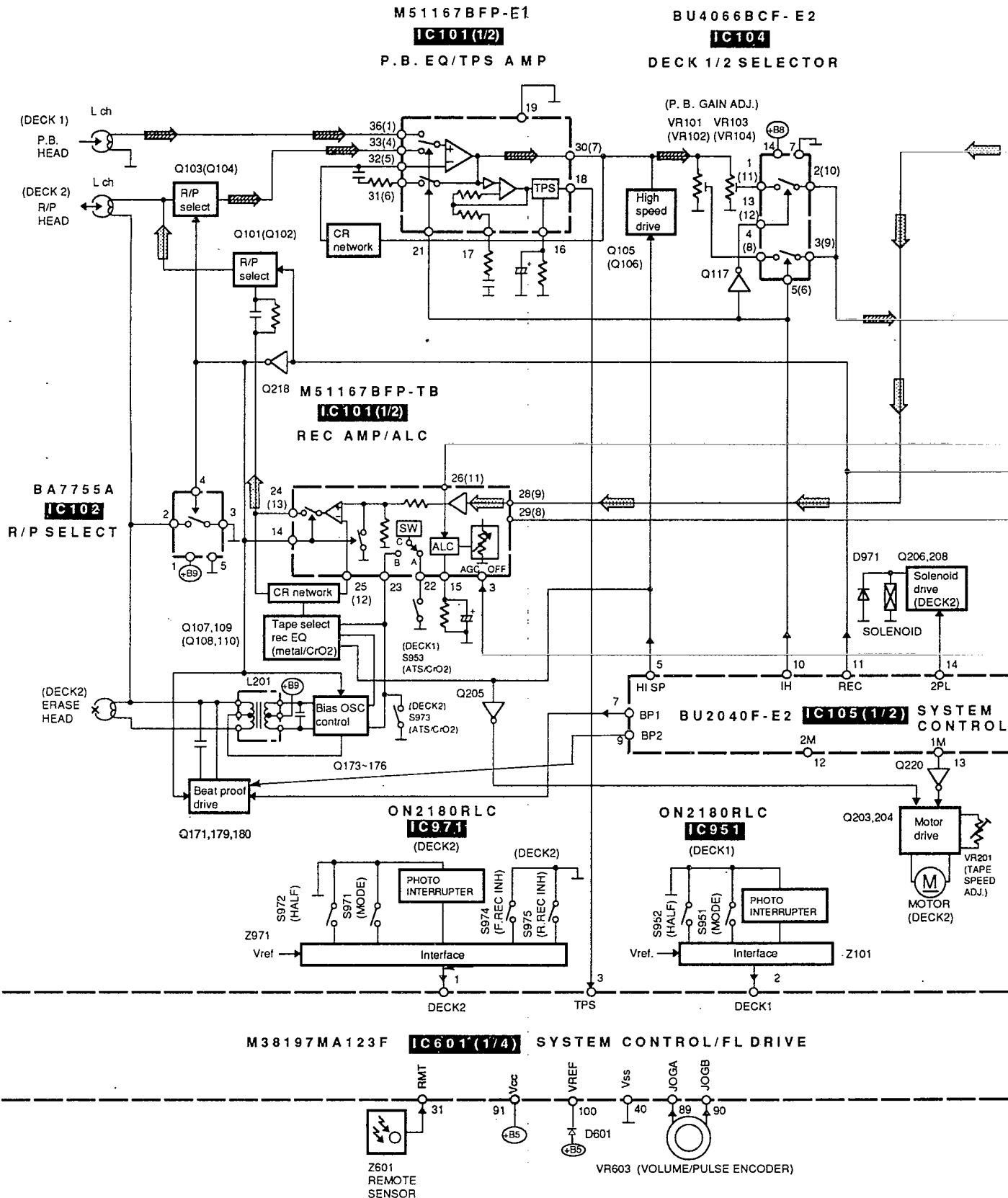

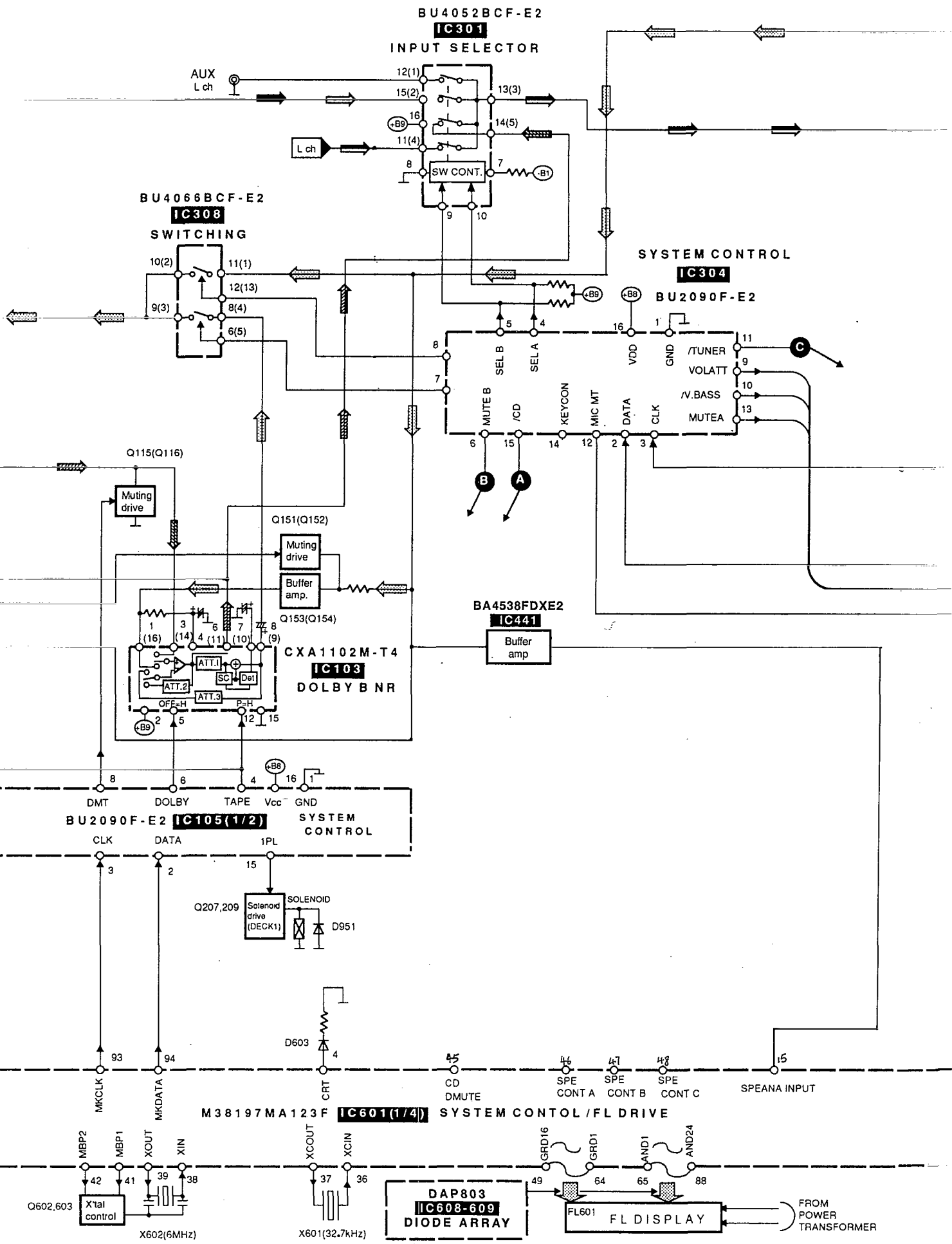

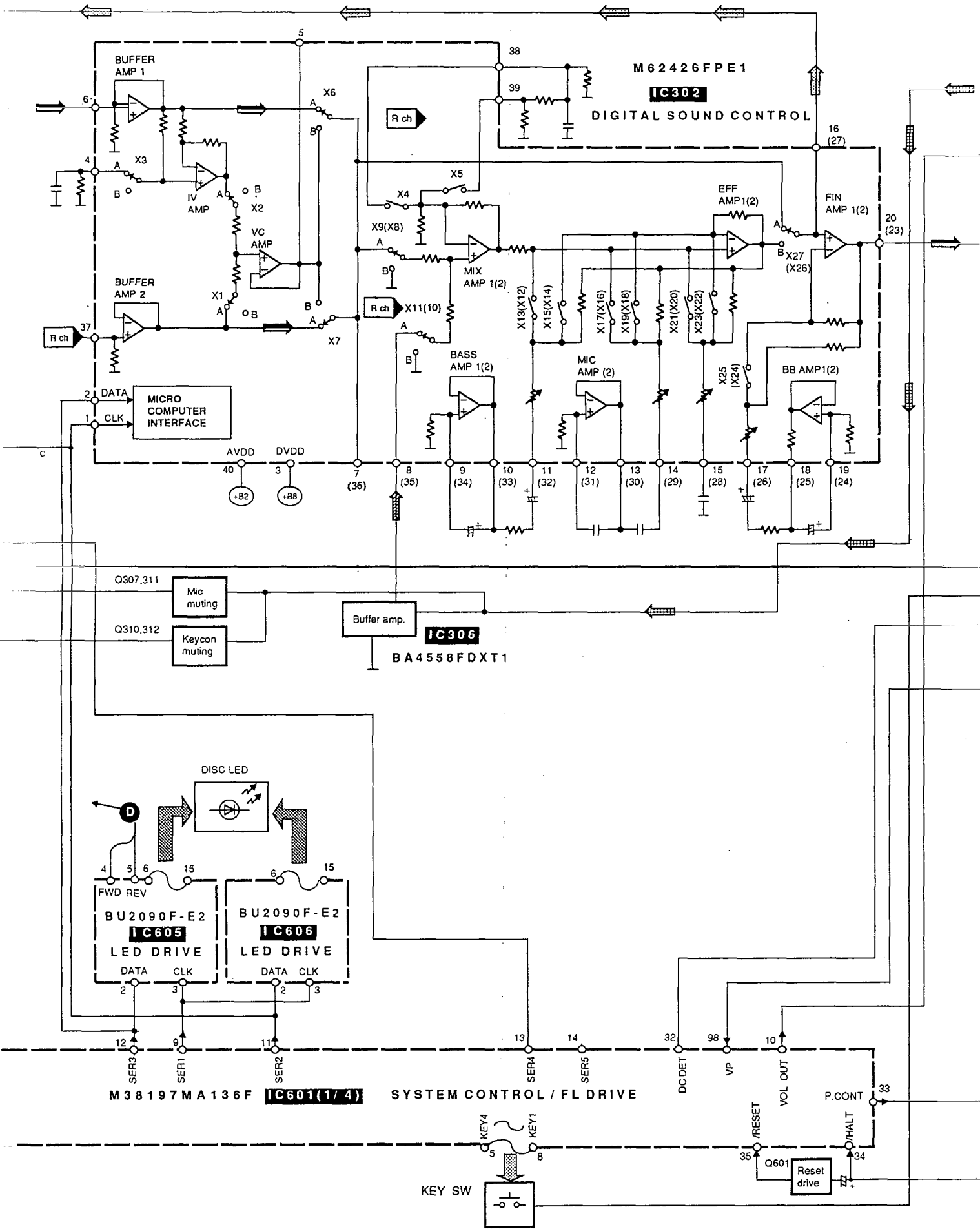

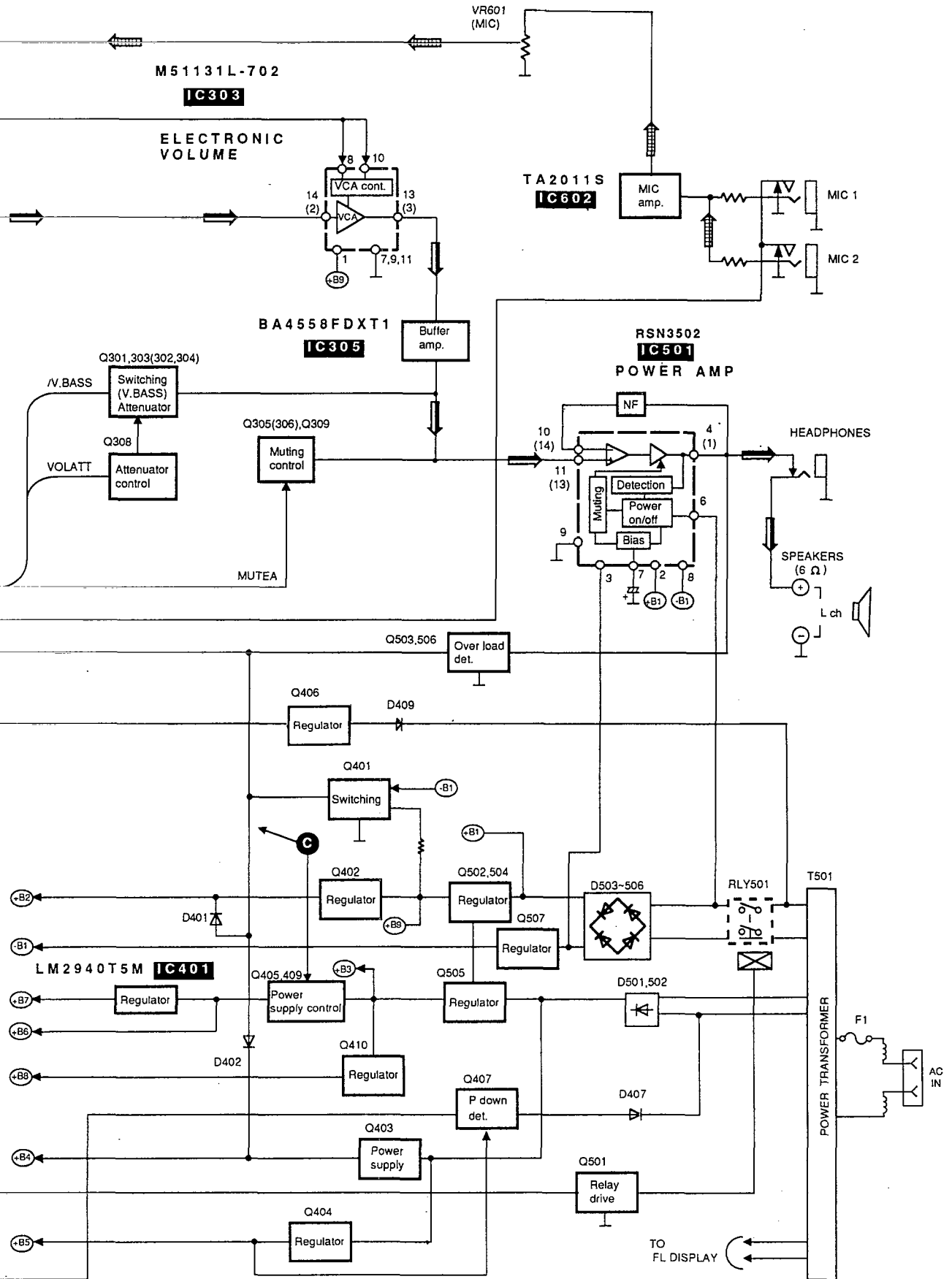

NOTE:
 FM SIGNAL LINE
 AM SIGNAL LINE
 CD SIGNAL LINE
 RECORDING SIGNAL LINE
 FM OSC SIGNAL LINE
 AM OSC SIGNAL LINE
 CD G SIGNAL LINE
 PLAYBACK SIGNAL LINE
 MIC SIGNAL

■ Printed Circuit Board

▲ SERVO P.C.B. (REPX0109)

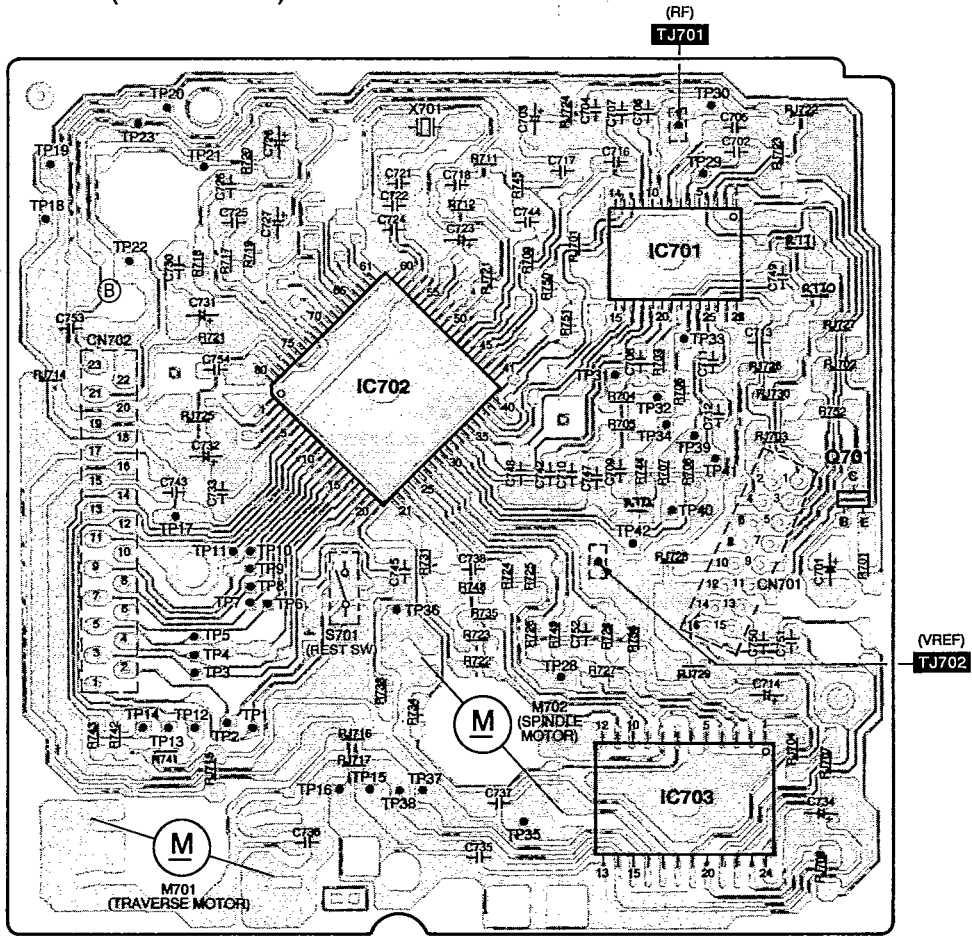

○ LOADING MOTOR P.C.B. (REP2182A-N)

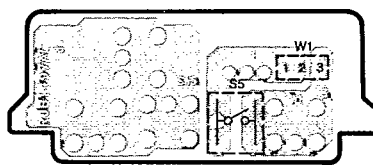
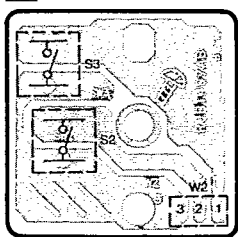
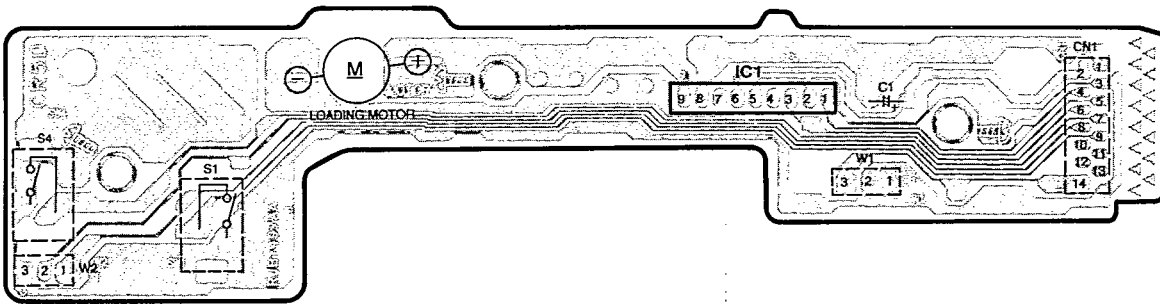

D MAIN P.C.B. (REP2196D)

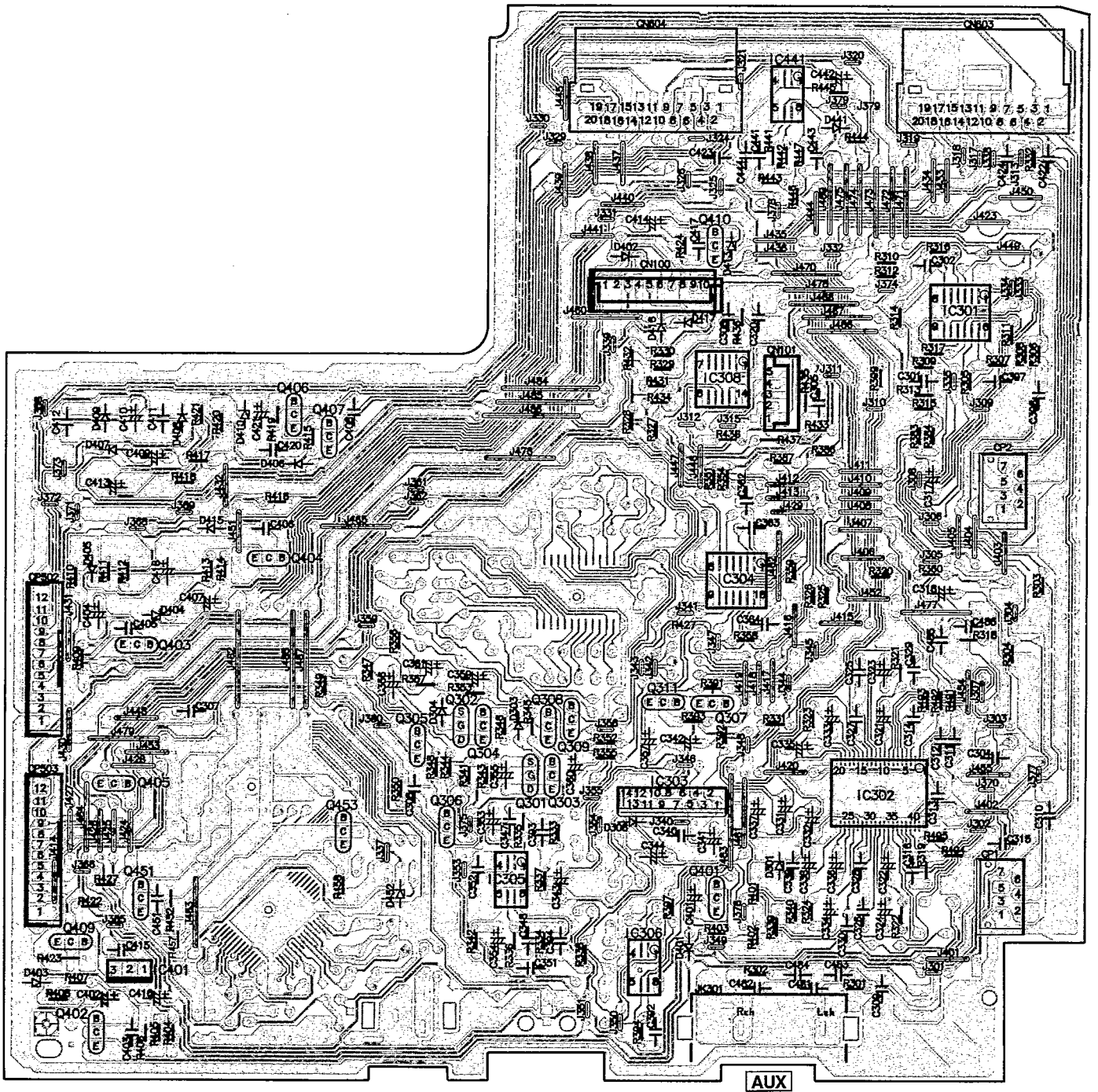

B TUNER P.C.B. (REP2000G)

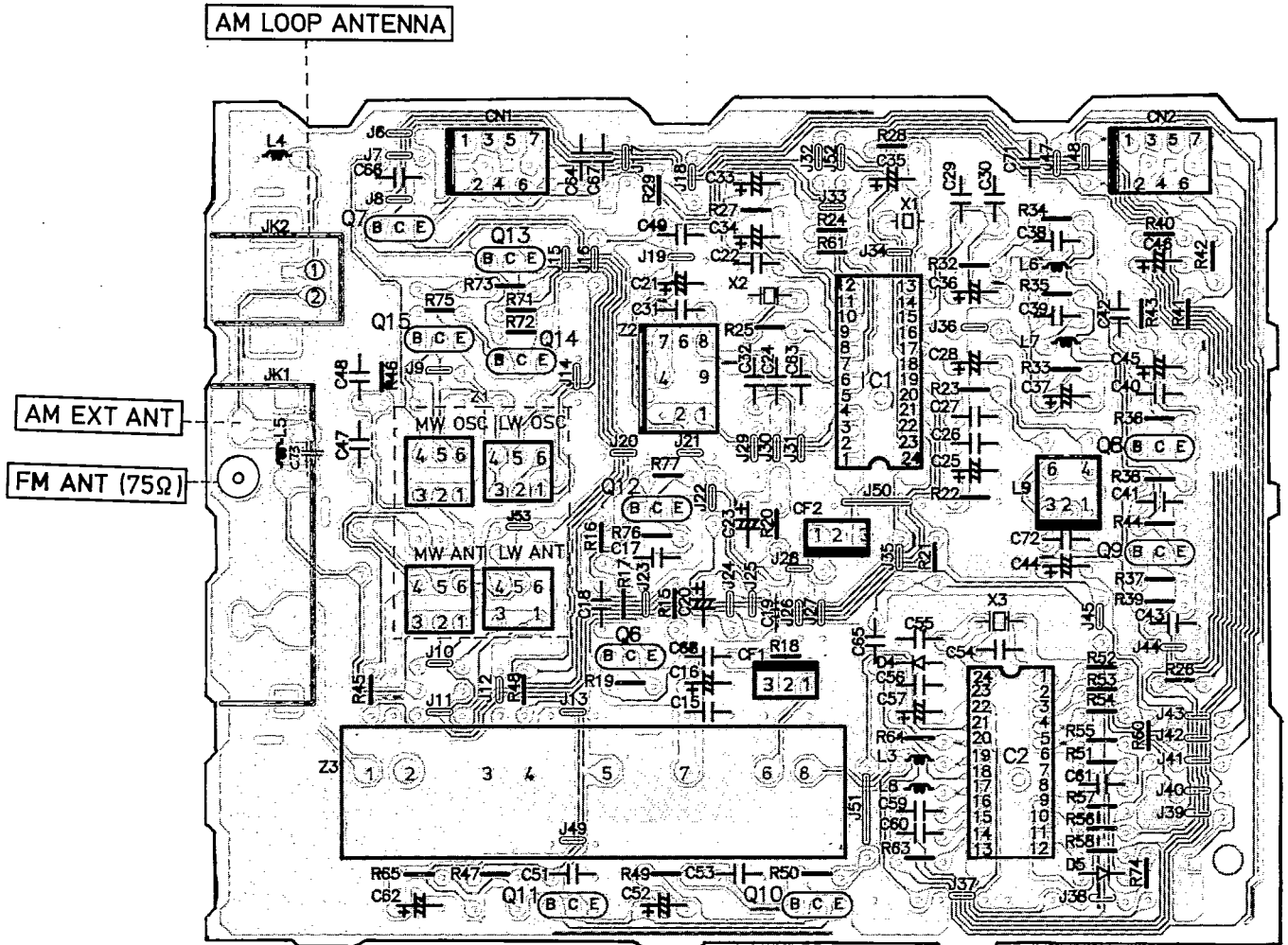

M MECHANISM (DECK 1) P.C.B. (REPX0108A)

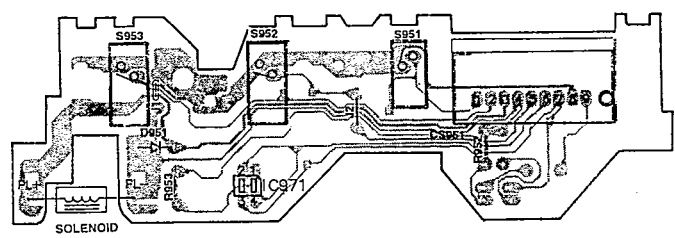

N MECHANISM (DECK 2) P.C.B. (REPX0108)

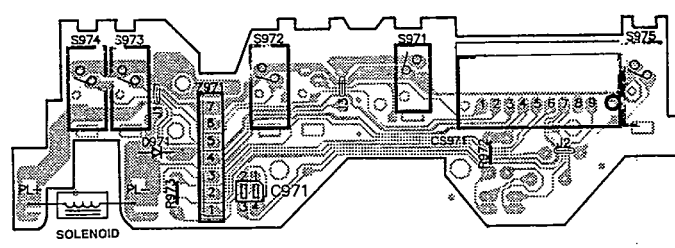

E PANEL P.C.B. (REP2199D)

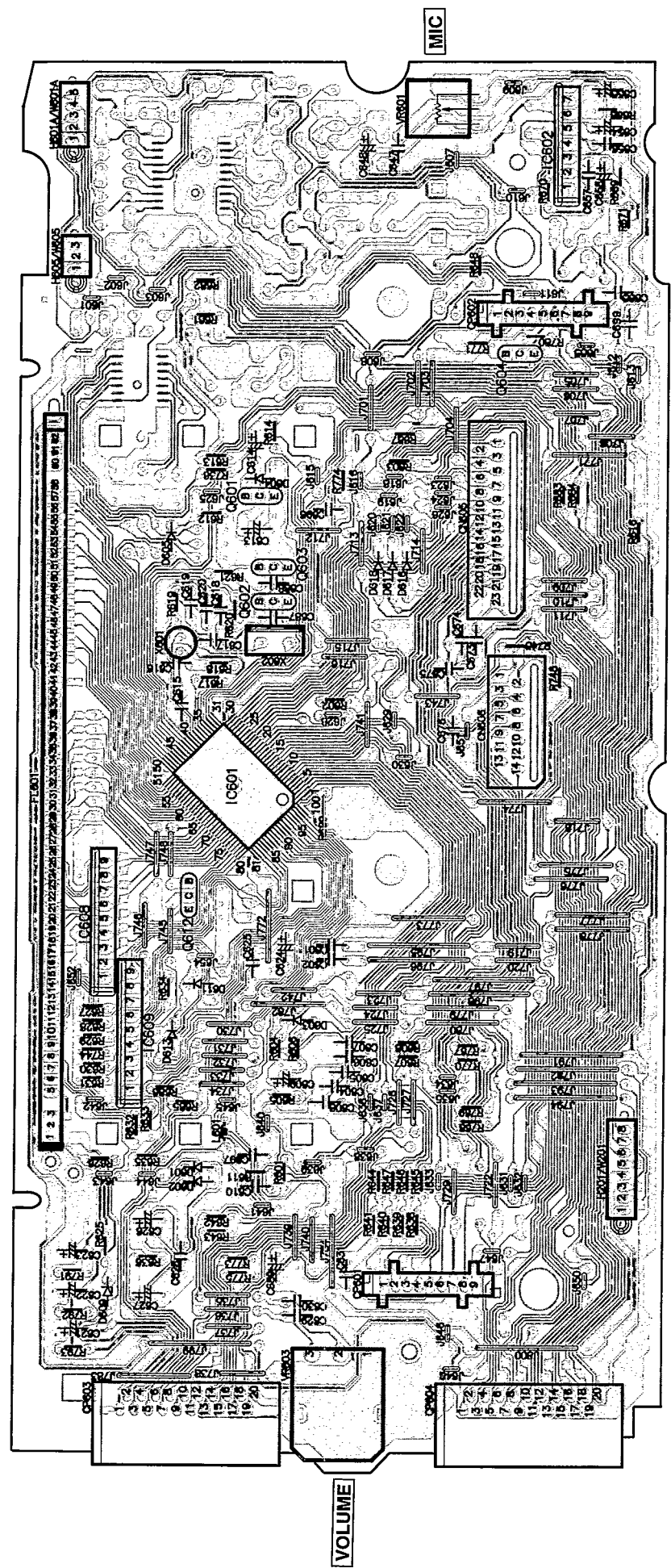

G OPERATION P.C.B. (REP2199D)

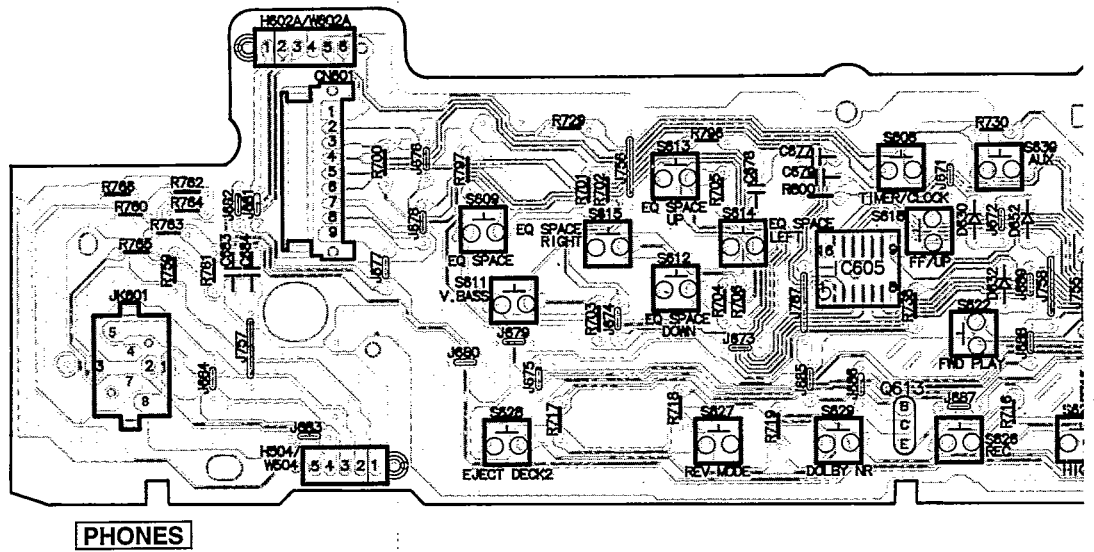

PHONES

C DECK P.C.B. (REP2200C)

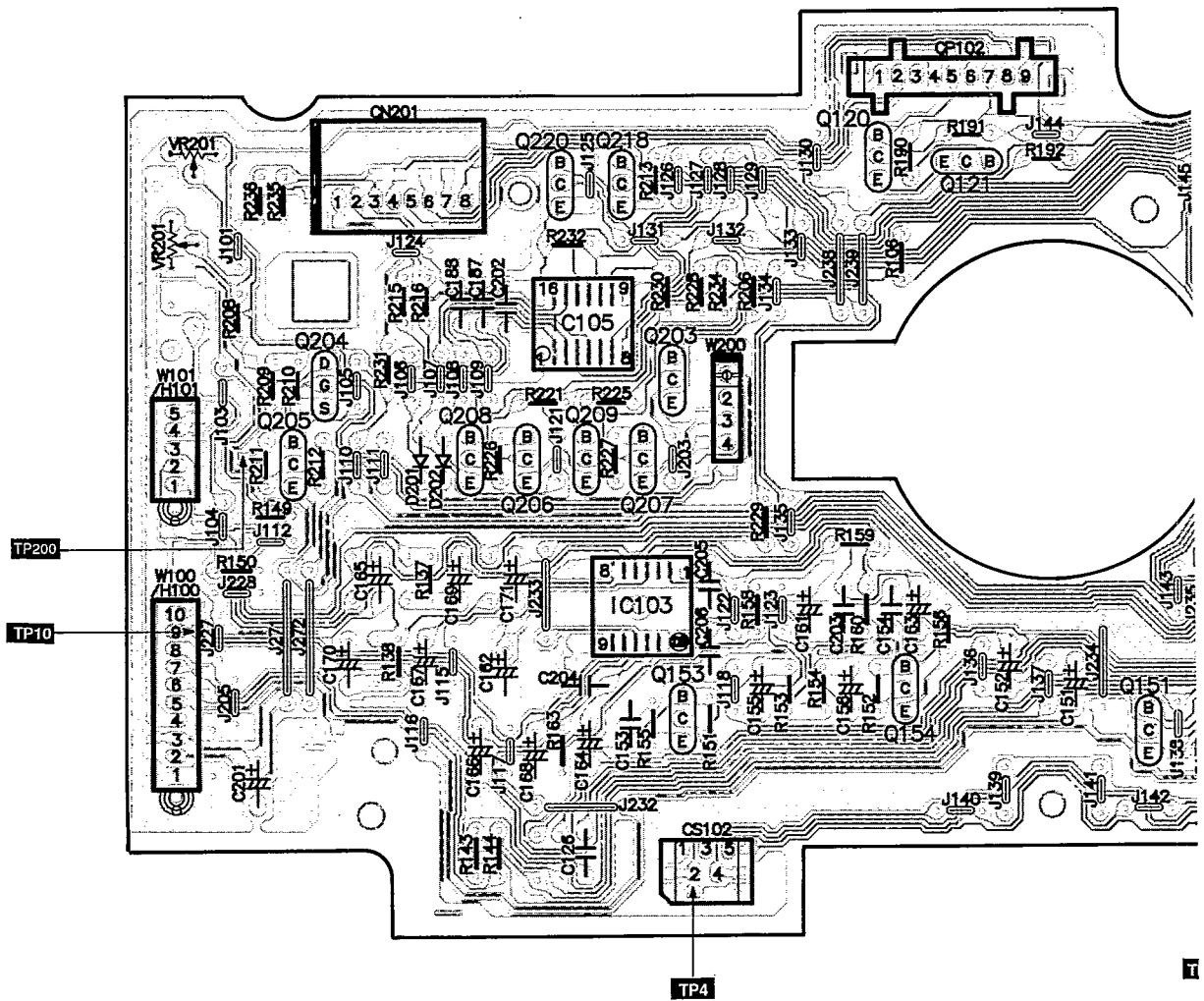

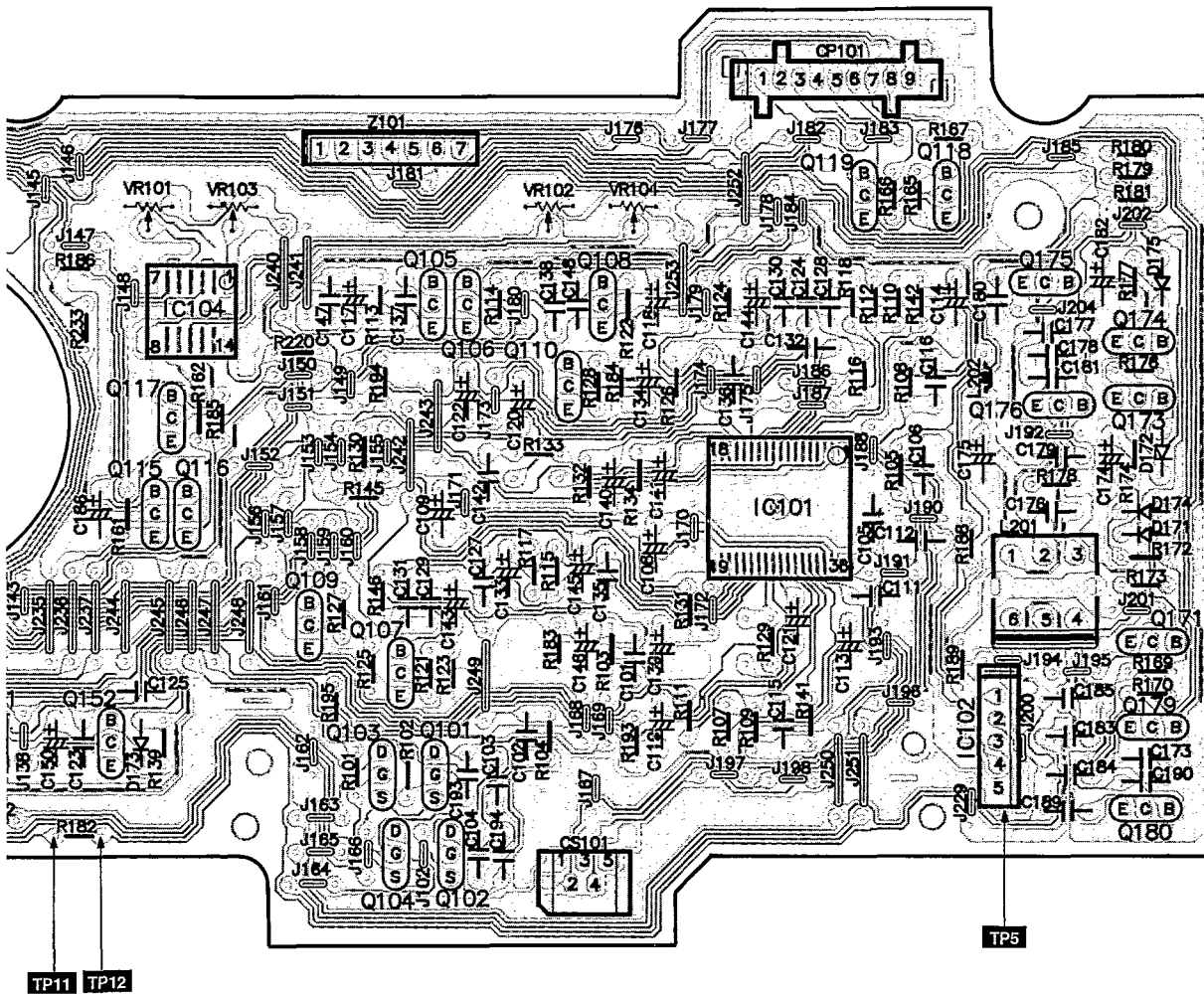
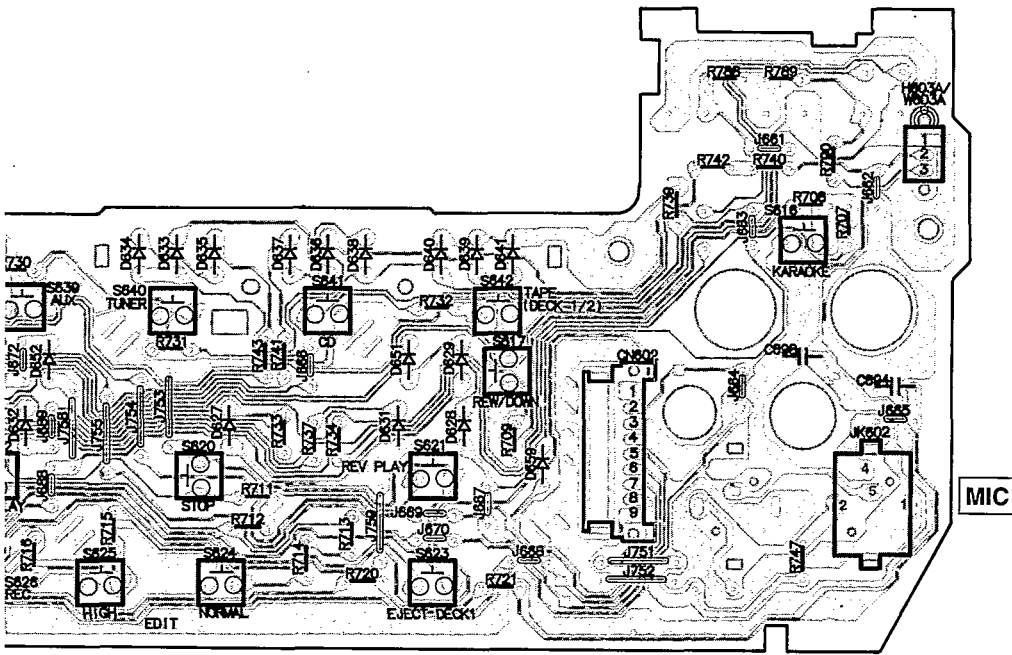

F LED P.C.B. (REP2199D)

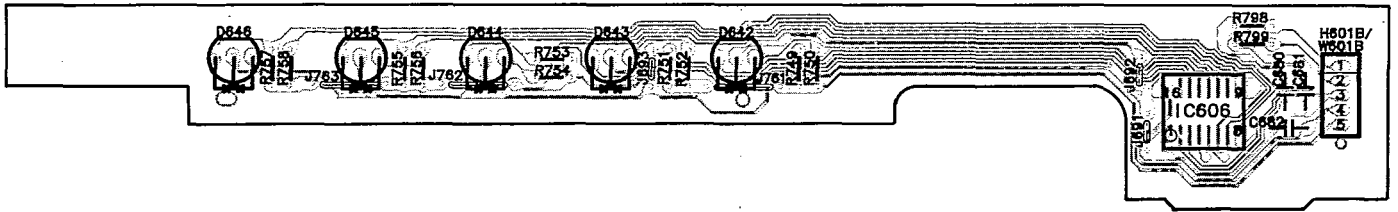

H SENSOR P.C.B. (REP2199D)

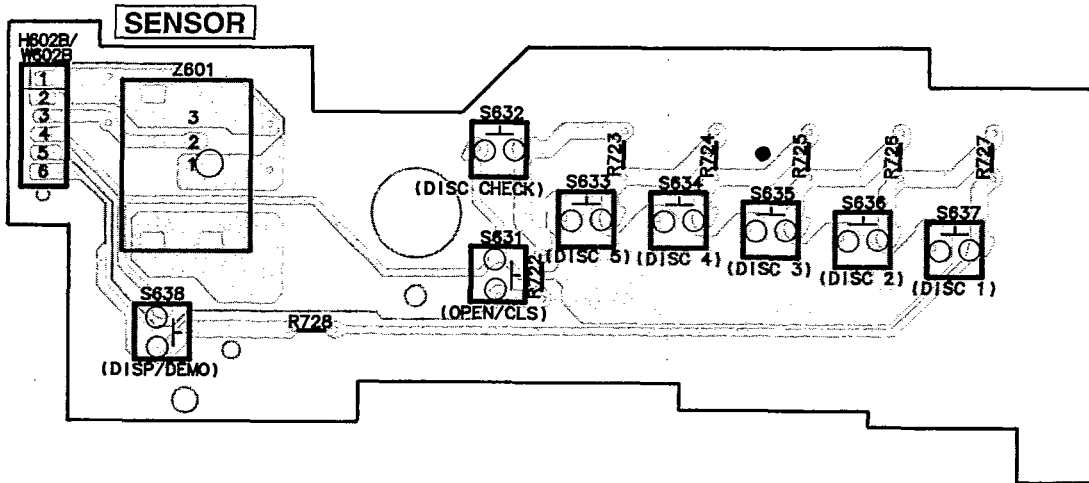

I OPERATION(POWER) P.C.B. (REP2199D)

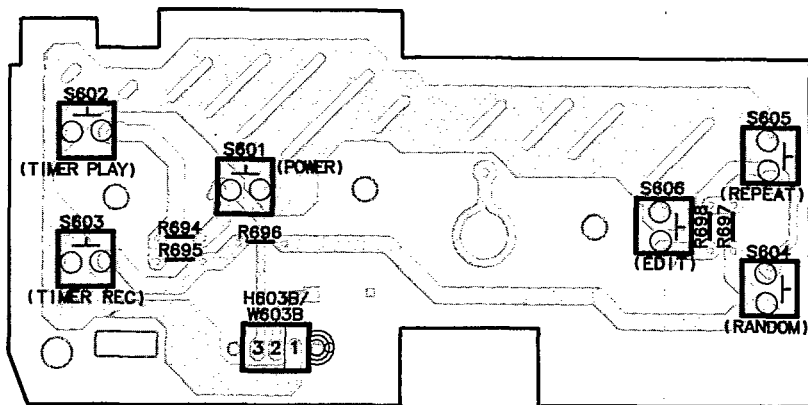

J BACK LIGHT P.C.B. (REP2196D)

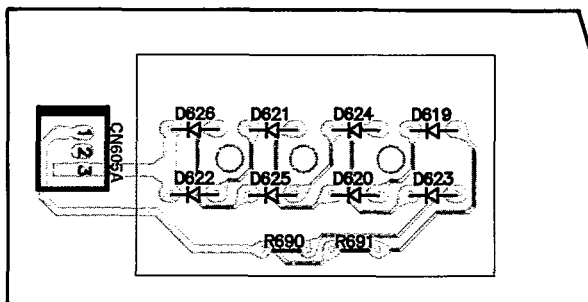

K POWER P.C.B. (REP2197C) E, EG
(REP2197D) EB

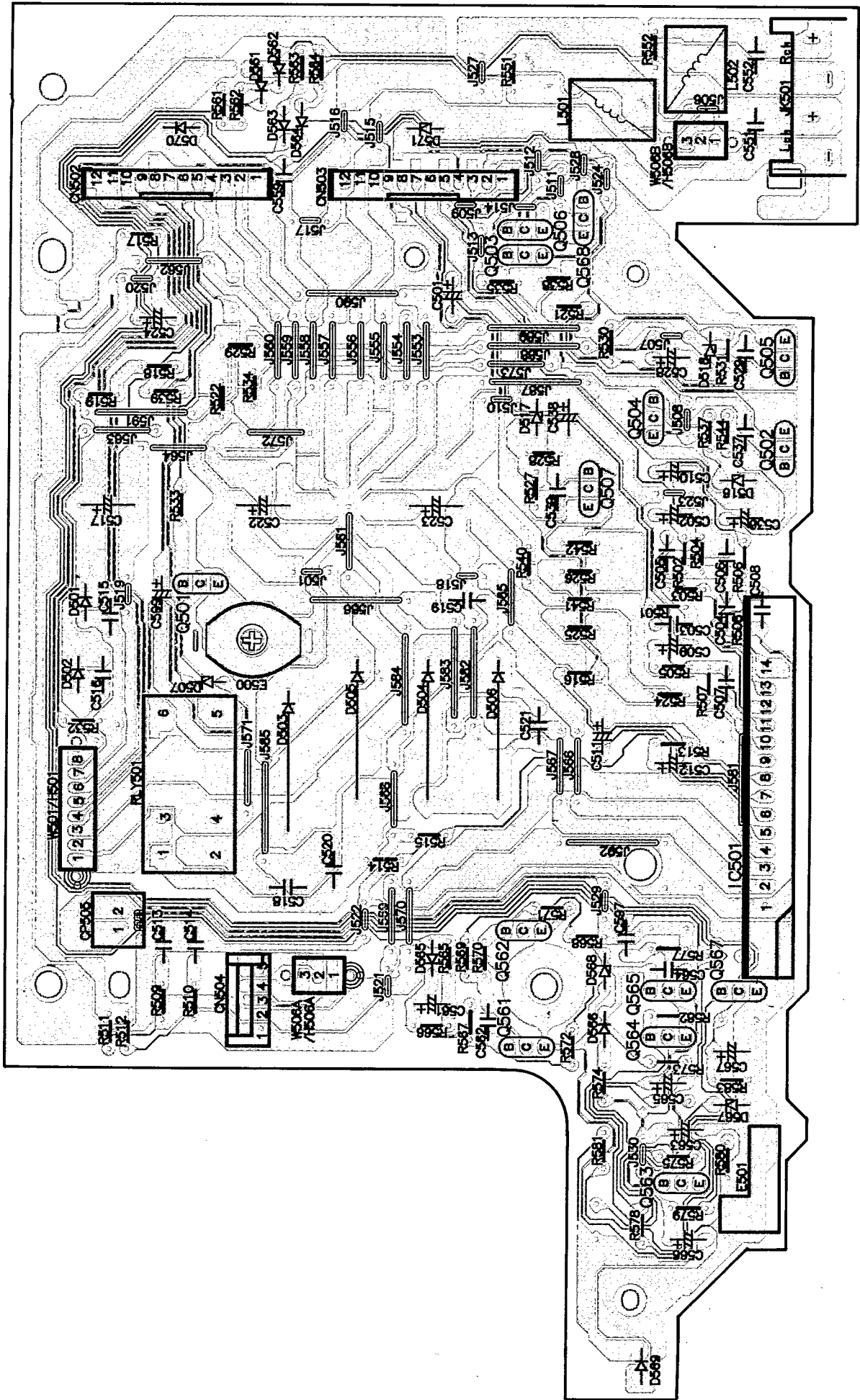

SPEAKERS

L TRANSFORMER P.C.B. (REP2197C) E, EG

CAUTION
RISK OF ELECTRIC SHOCK
 AC voltage line. Please do not touch this pcb.

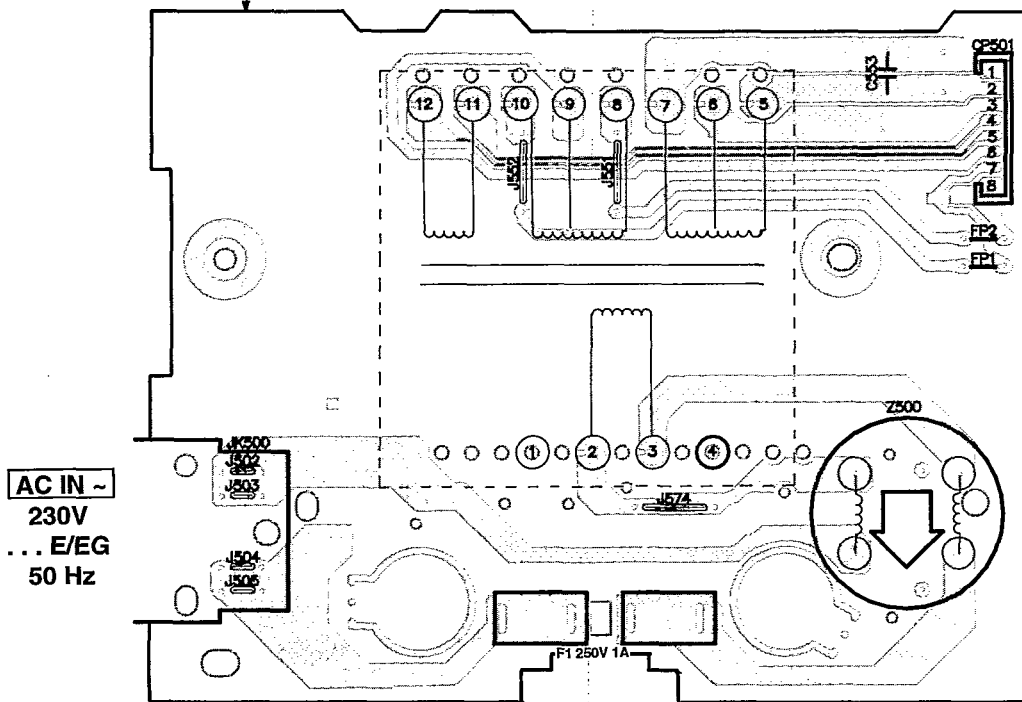

L TRANSFORMER P.C.B. (REP2197D) EB

CAUTION
RISK OF ELECTRIC SHOCK
 AC voltage line. Please do not touch this pcb.

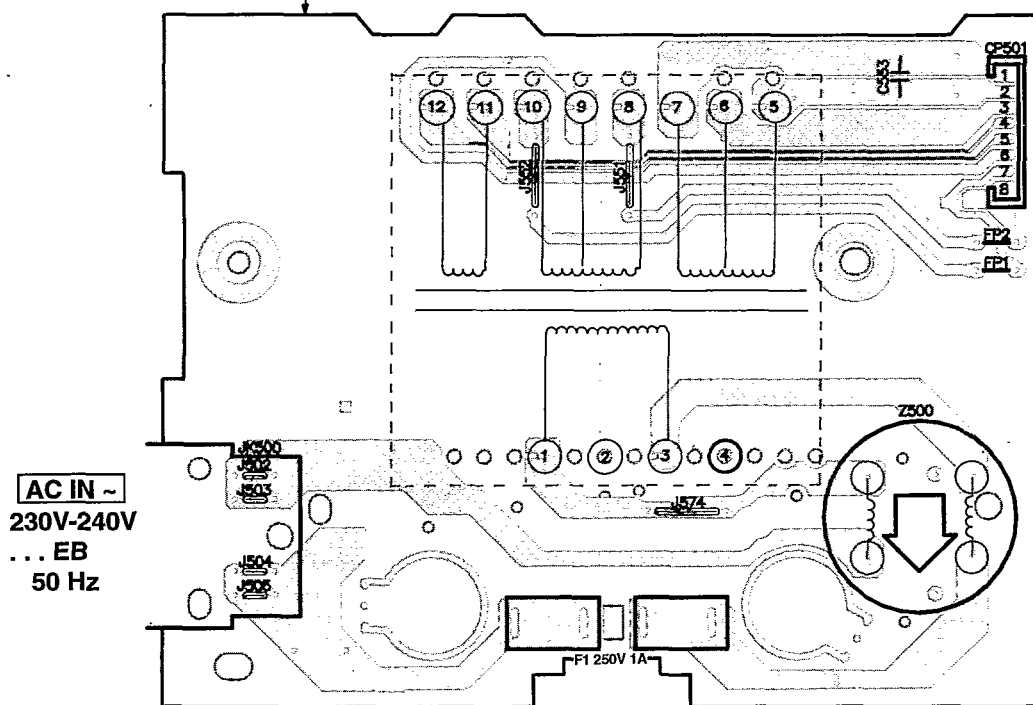

■ Schematic Diagram

(All schematic diagrams may be modified at any time with the development of new technology)

Note :

< for Servo circuit > (Page 41)

- S701 : Reset switch

< for Panel circuit, Sensor Circuit, Operation Circuit and Operation(Power) circuit > (Page 44 – 46)

- | | | | | | |
|--------|---|------------------------|---------|---|-------------------------|
| • S601 | : | Power switch | • S624 | : | Tape Edit Normal switch |
| • S602 | : | Timer Play switch | • S625 | : | Tape Edit High switch |
| • S603 | : | Timer Record switch | • S626 | : | Record switch |
| • S604 | : | Random switch | • S627 | : | Reverse Mode switch |
| • S605 | : | Repeat switch | • S628 | : | Eject Deck 2 switch |
| • S606 | : | Easy Edit switch | • S629 | : | DOLBY NR switch |
| • S608 | : | Clock/Timer switch | • S631 | : | CD Open/Close switch |
| • S609 | : | EQ. Space switch | • S632 | : | CD Disc Check switch |
| • S611 | : | V. Bass switch | • S633 | : | CD Disc 5 switch |
| • S612 | : | EQ. Space Down switch | • S634 | : | CD Disc 4 switch |
| • S613 | : | EQ. Space Up switch | • S635 | : | CD Disc 3 switch |
| • S614 | : | EQ. Space Left switch | • S636 | : | CD Disc 2 switch |
| • S615 | : | EQ. Space Right switch | • S637 | : | CD Disc 1 switch |
| • S616 | : | Karaoke switch | • S638 | : | Display/Demo switch |
| • S617 | : | REW/Down switch | • S639 | : | AUX switch |
| • S618 | : | FF/Up switch | • S640 | : | Tuner switch |
| • S620 | : | Stop switch | • S641 | : | CD switch |
| • S621 | : | Reverse Play switch | • S642 | : | Deck 1/2 switch |
| • S622 | : | Forward Play switch | • VR601 | : | Mic control |
| • S623 | : | Eject Deck 1 switch | • VR603 | : | Volume control |













< for Deck circuit, Mechanism (Deck 1) circuit and Mechanism (Deck 2) circuit > (Page 51 – 53)

- | | | | | | |
|--------|---|--|---------|---|---|
| • S951 | : | Deck 1 Mode detect switch. | • S975 | : | Deck 2 Record detect switch. |
| • S952 | : | Deck 1 Tape detect switch. | • VR101 | : | Deck 1 Lch playback gain adjustment VR (DOLBY). |
| • S953 | : | Deck 1 CrO ₂ detect switch. | • VR102 | : | Deck 1 Rch playback gain adjustment VR (DOLBY). |
| • S971 | : | Deck 2 Mode detect switch. | • VR103 | : | Deck 2 Lch playback gain adjustment VR (DOLBY). |
| • S972 | : | Deck 2 Tape detect switch. | • VR104 | : | Deck 2 Rch playback gain adjustment VR (DOLBY). |
| • S973 | : | Deck 2 CrO ₂ detect switch. | • VR201 | : | Deck 2 Normal speed adjustment. |
| • S974 | : | Deck 2 Record detect switch. | | | |

< for Loading Motor circuit > (Page 55)

- S1, S4 : Leaf switch.
- S2, S3, S5 : Mecha switch.

•Signal line

- | | | | | | | | | |
|--|---|-------------------|---|---|----------------------|---|---|--------------------|
|  | : | +B line |  | : | Playback signal line |  | : | AM signal line |
|  | : | -B line |  | : | Record signal line |  | : | AM OSC signal line |
|  | : | FM/AM signal line |  | : | CD signal line |  | : | FM OSC signal line |
|  | : | Main signal line |  | : | FM signal line |  | : | Aux signal line |

•The voltage value and waveforms are the reference voltage of this unit measured by DC electronic voltmeter (high impedance) and oscilloscope on the basis of chassis.

Accordingly, there may arise some error in voltage values and waveforms depending upon the internal impedance of the tester or the measuring unit.

No mark : Playback << >>.....Rec { } : Tuner (()) : CD () AM < > FM

•Importance safety notice:

Components identified by  mark have special characteristics important for safety. Furthermore, special parts which have purposes of fire-retardant (resistors), high-quality sound (capacitors), low-noise (resistors), etc. are used. When replacing any of components, be sure to use only manufacturer's specified parts shown in the parts list.

Caution !

- IC, LSI and VLSI are sensitive to static electricity.
- Secondary trouble can be prevented by taking care during repair.
- Cover the parts boxes made of plastics with aluminium foil.
- Put a conductive mat on the work table.
- Ground the soldering iron.
- Do not touch the pins of IC, LSI or VLSI with fingers directly.

Schematic Diagram

A SERVO CIRCUIT

OPTICAL PICKUP

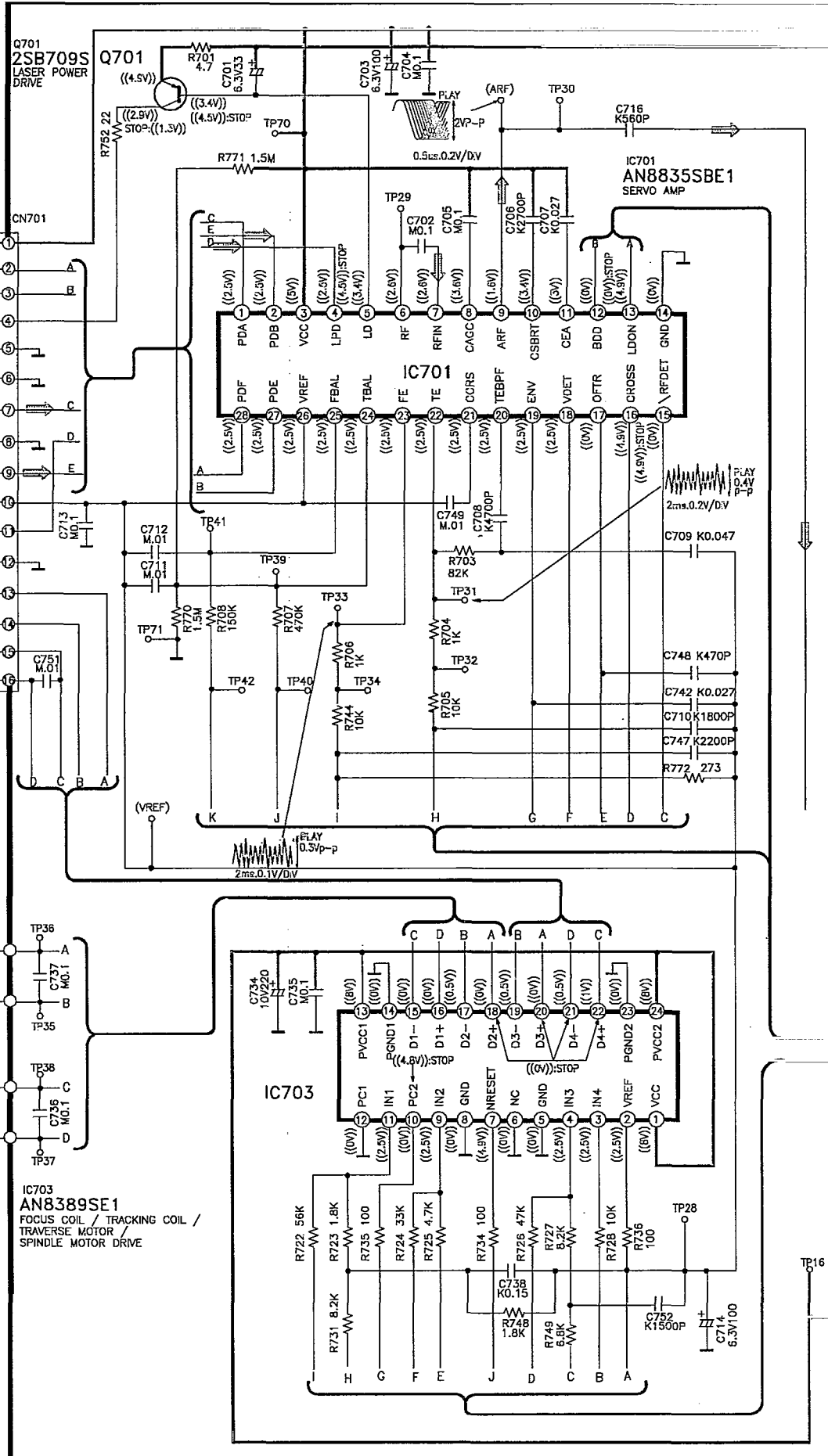
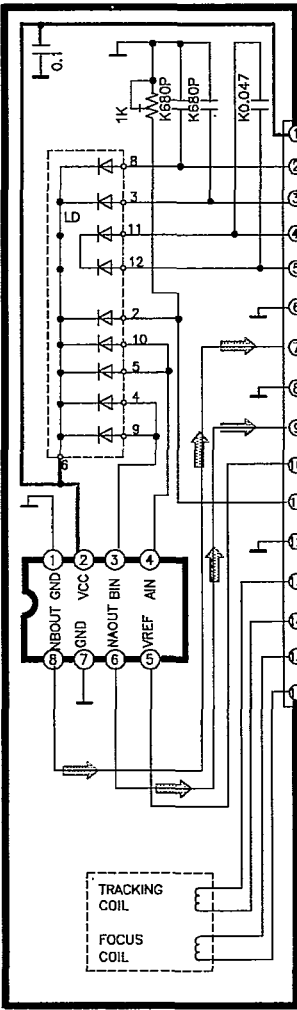

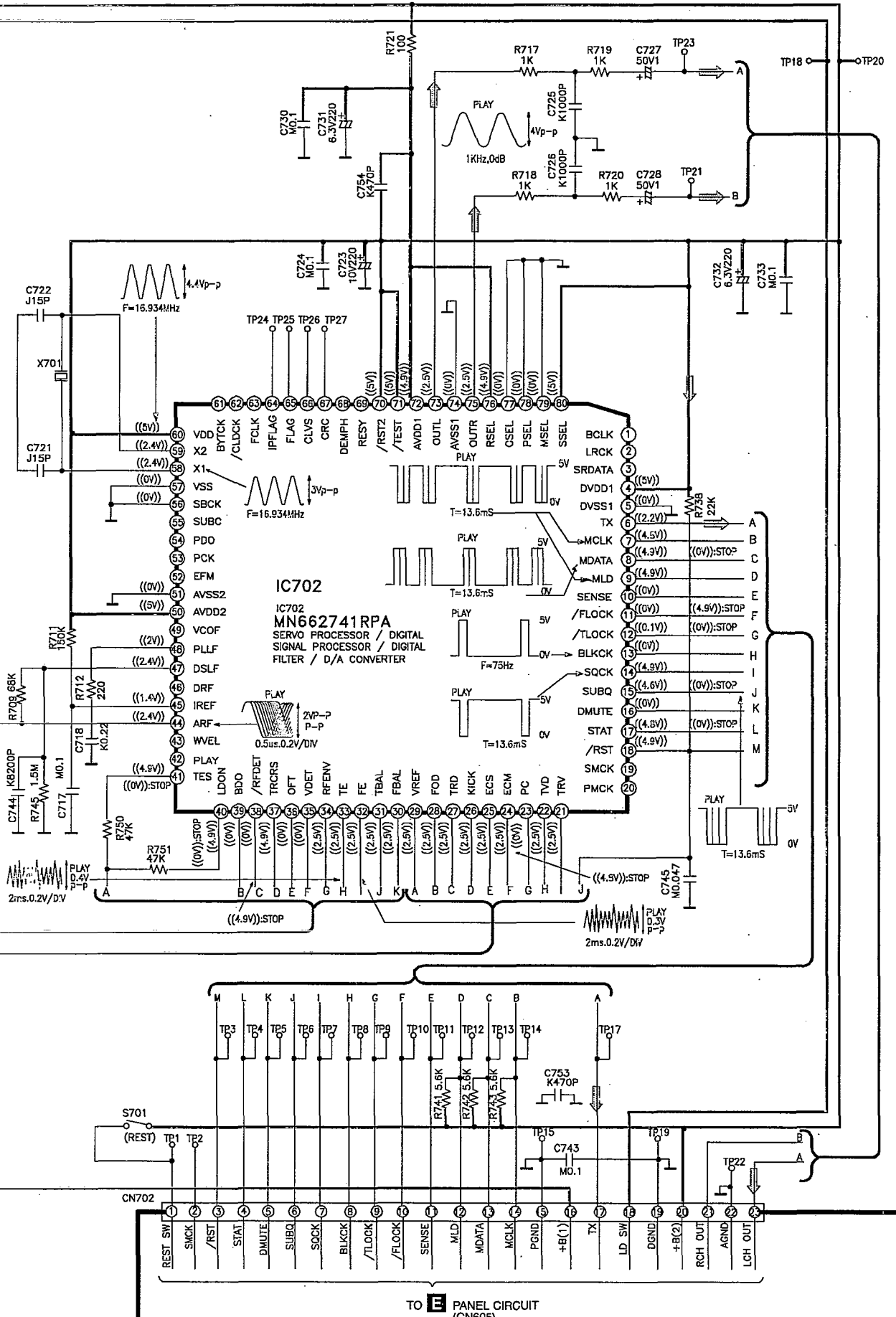

TO **E** PANEL CIRCUIT (CN605) (PAGE 47)

B TUNER CIRCUIT

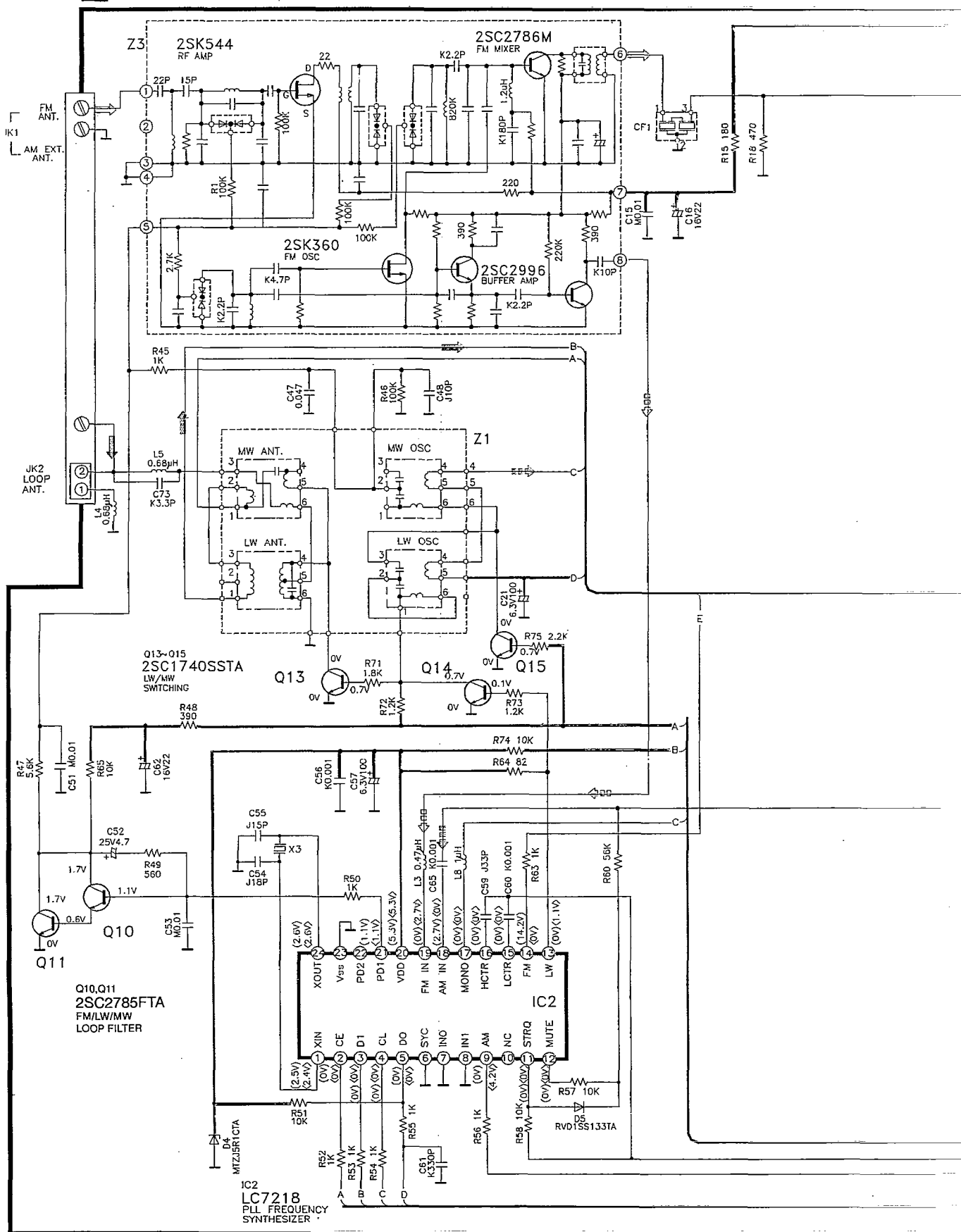

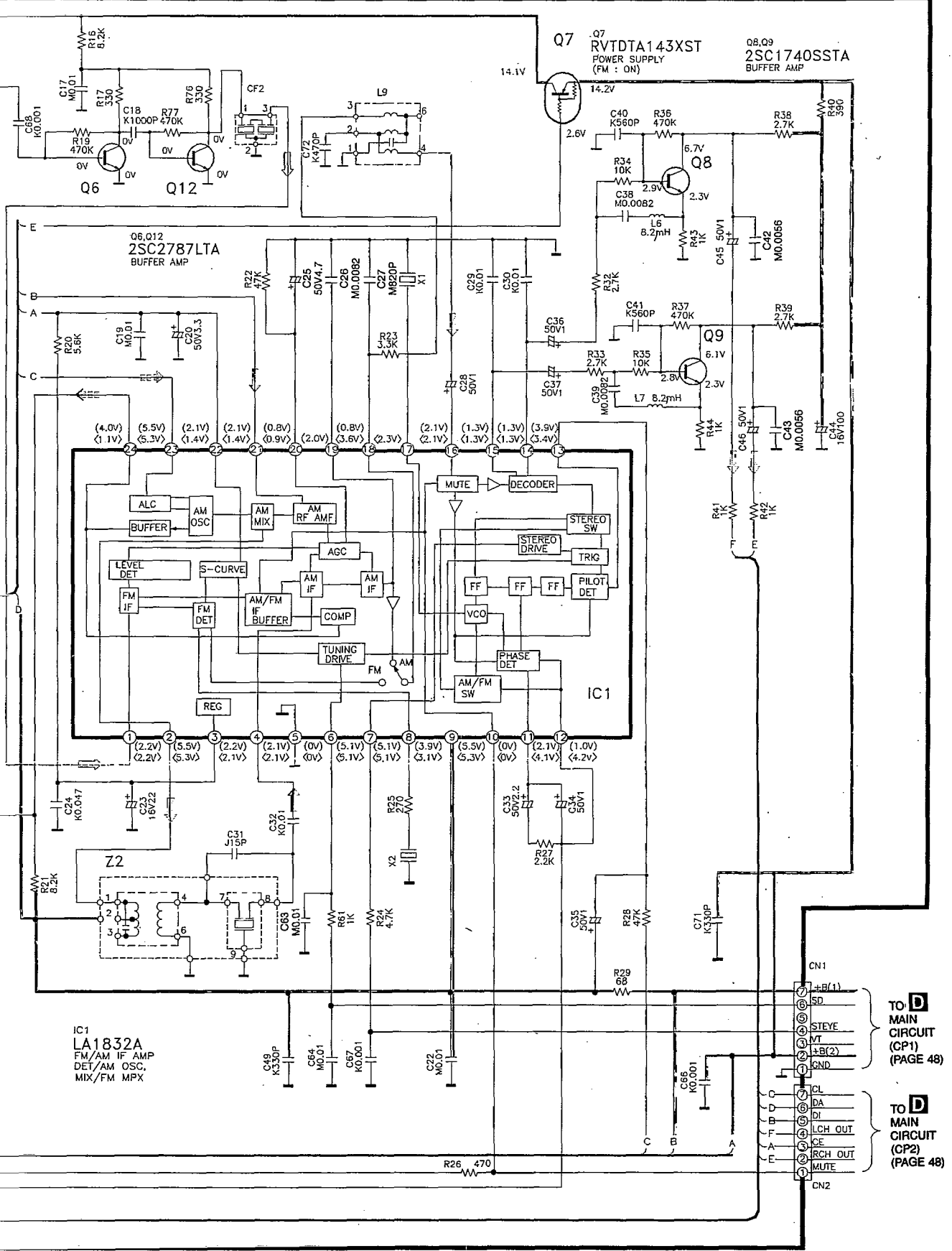

I OPERATION (POWER) CIRCUIT

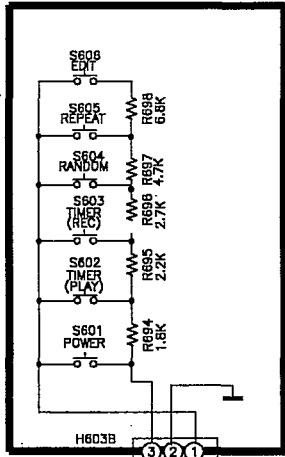

H SENSOR CIRCUIT

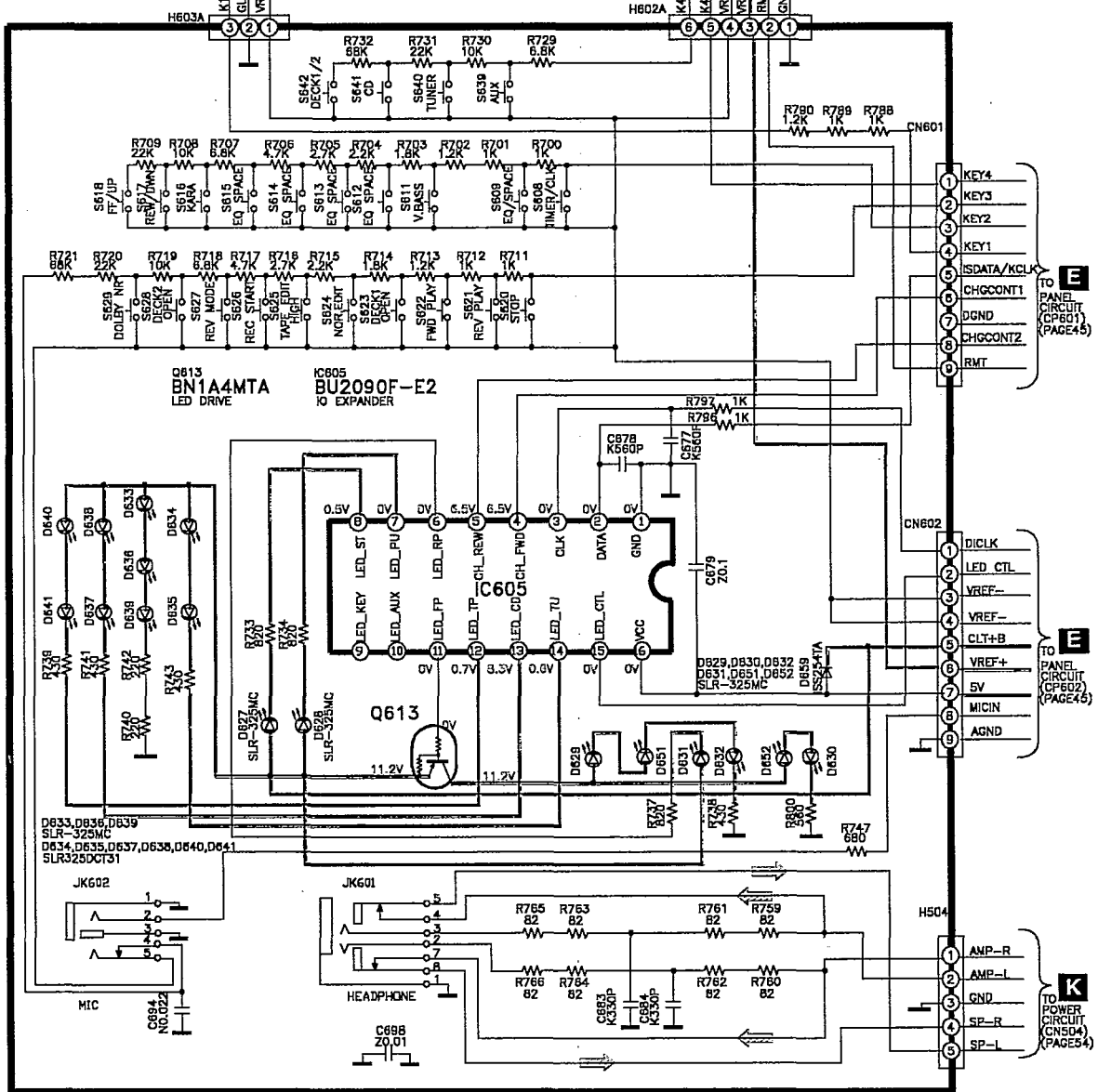
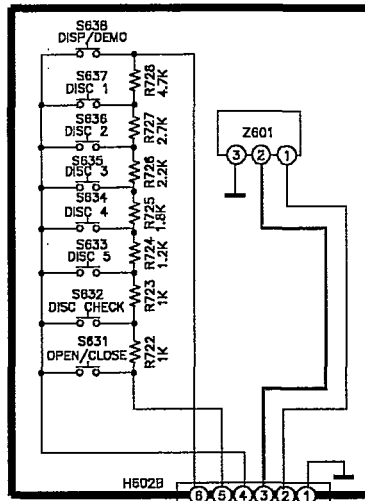

G OPERATION CIRCUIT

E PANEL CIRCUIT

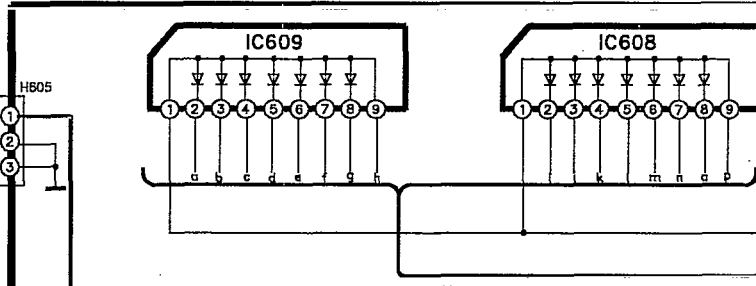

J
TO
BACK LIGHT
CIRCUIT
(CN605A)
(PAGE 50)

F LED CIRCUIT

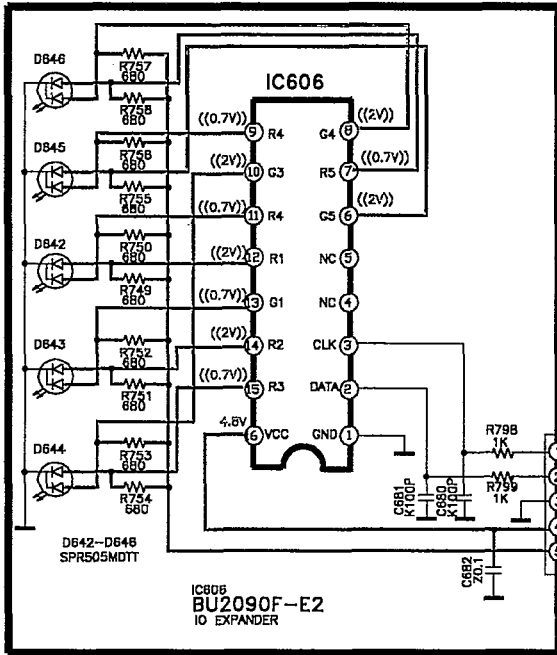

IC608, IC609
DAP803
SYSTEM DRIVE AND FL CONTROL

G
TO
OPERATION
CIRCUIT
(CN601)
(PAGE 44)

G
TO
OPERATION
CIRCUIT
(CN602)
(PAGE 44)

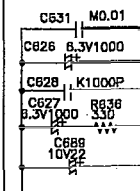
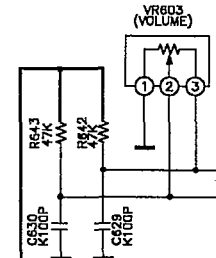
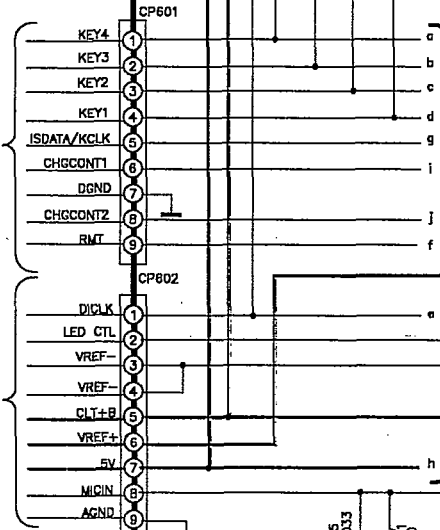

Q604
2SB621RTA
POWER SUPPLY

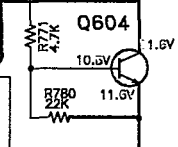

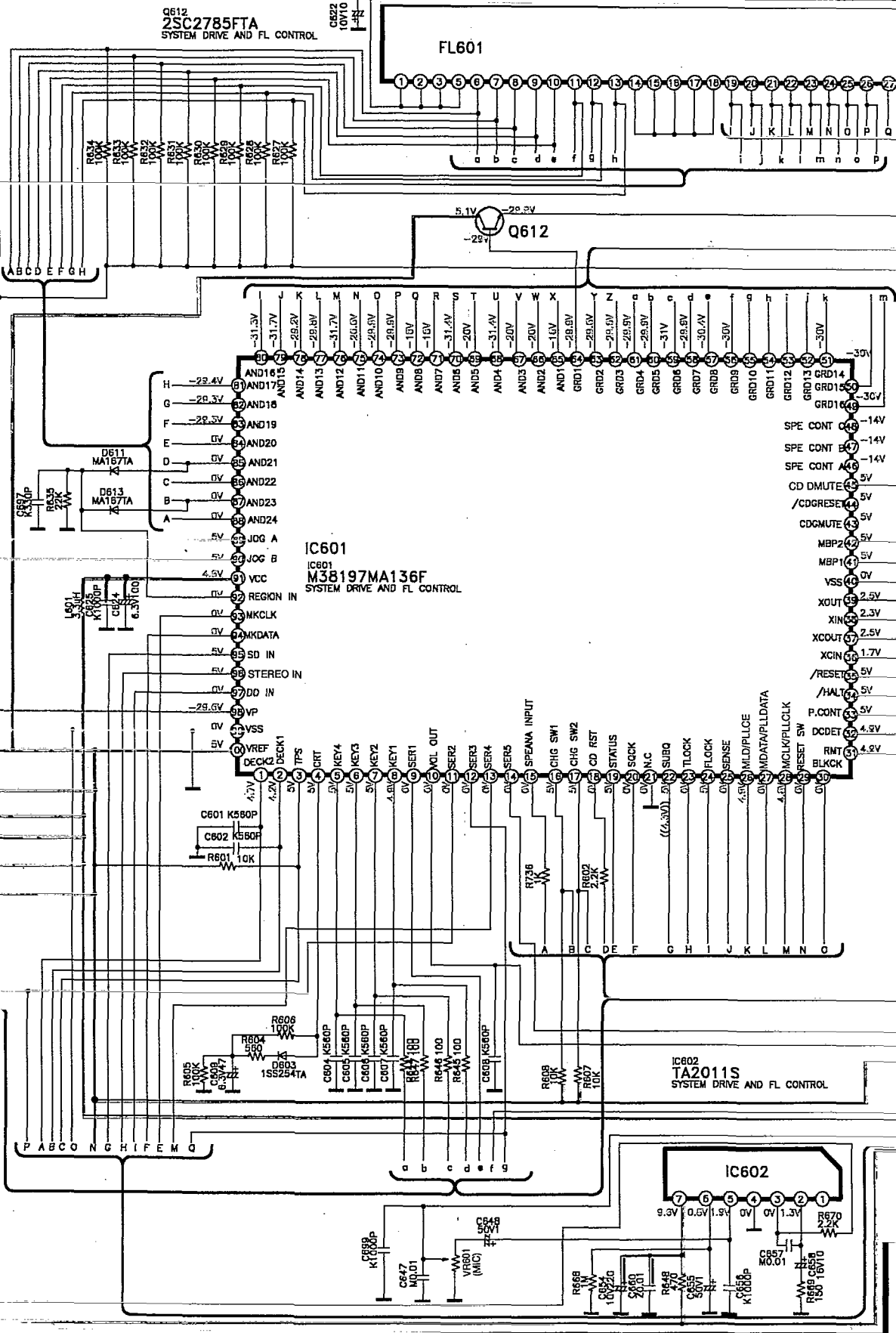

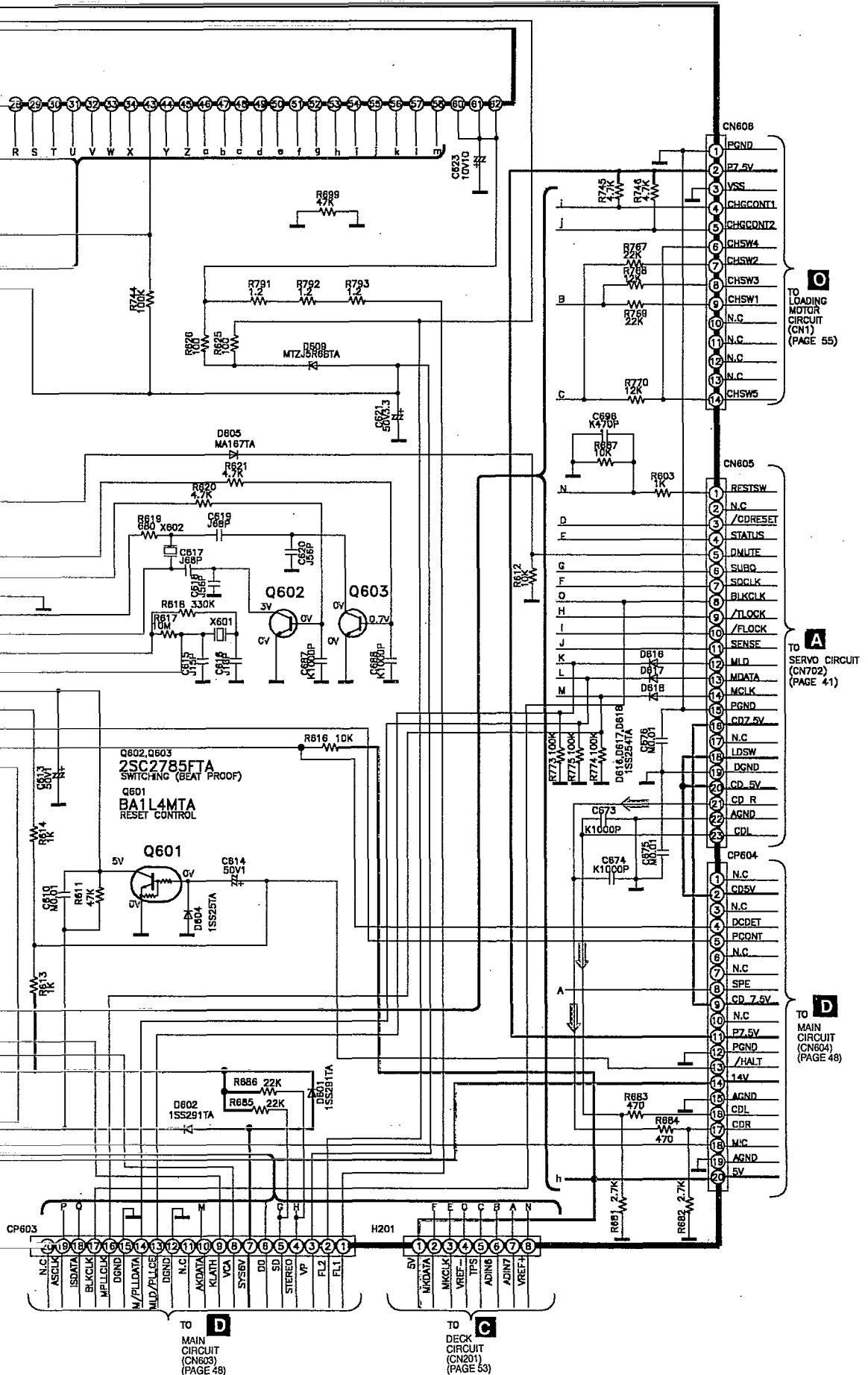

D MAIN CIRCUIT

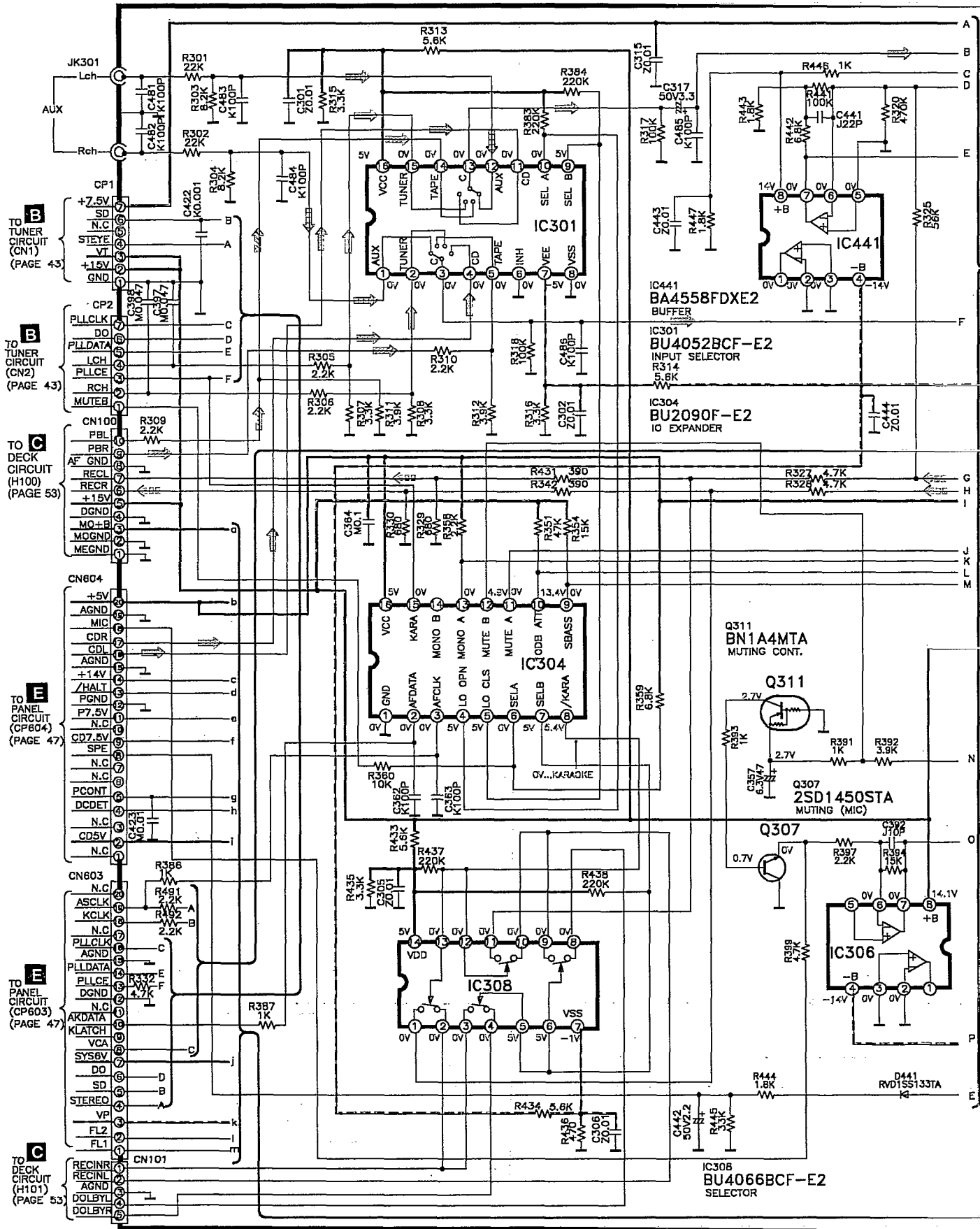

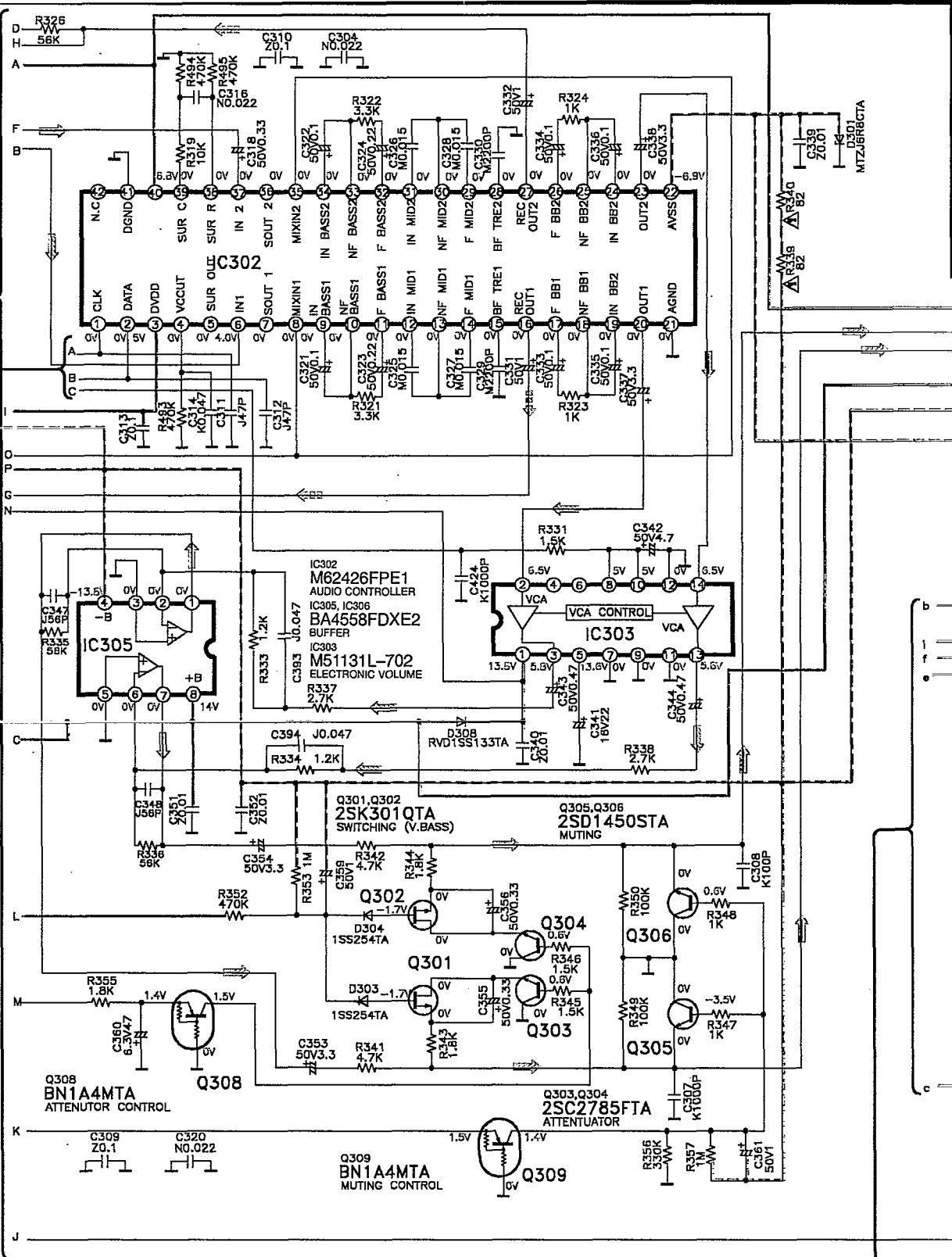

J BACK LIGHT CIRCUIT

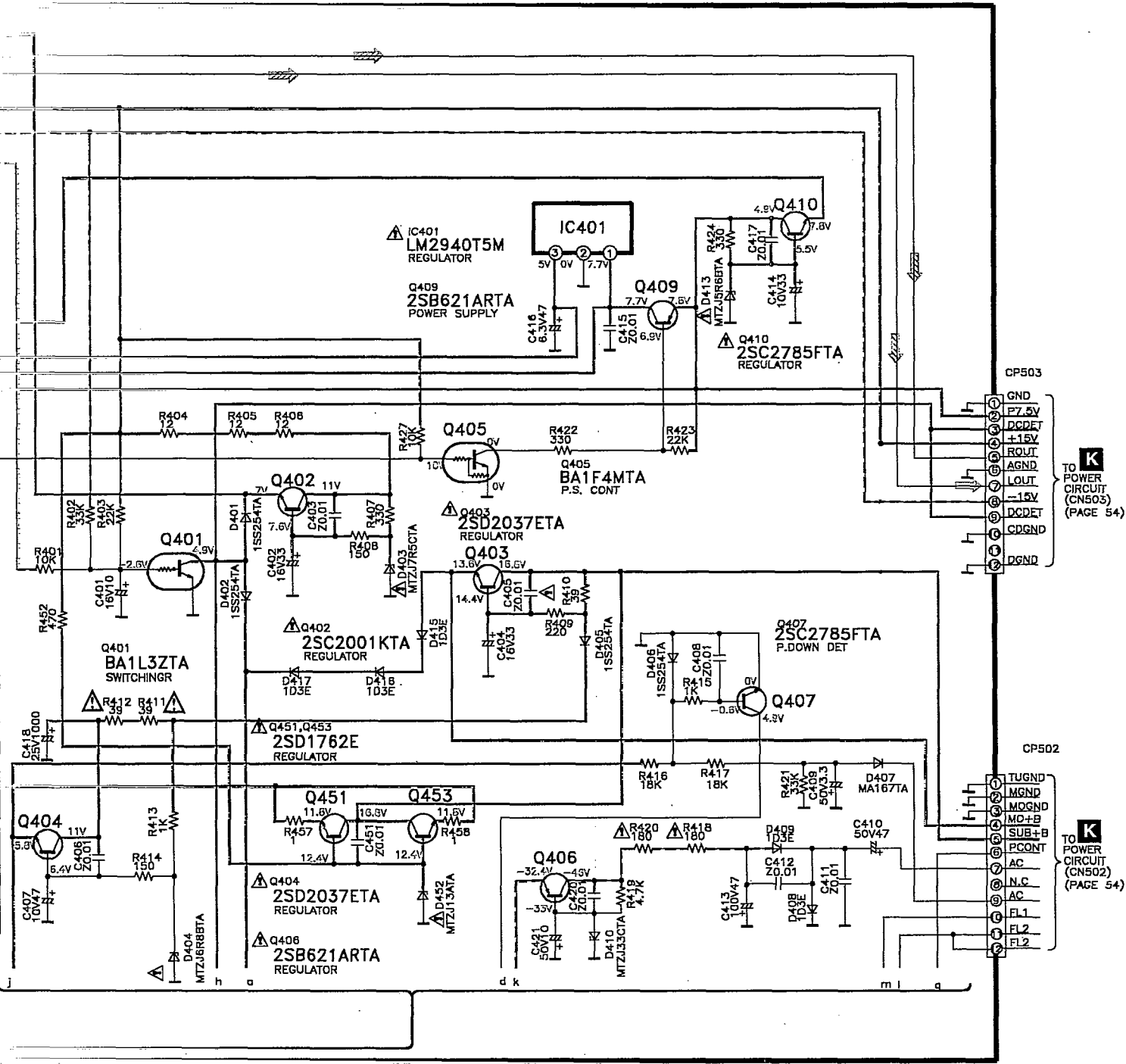
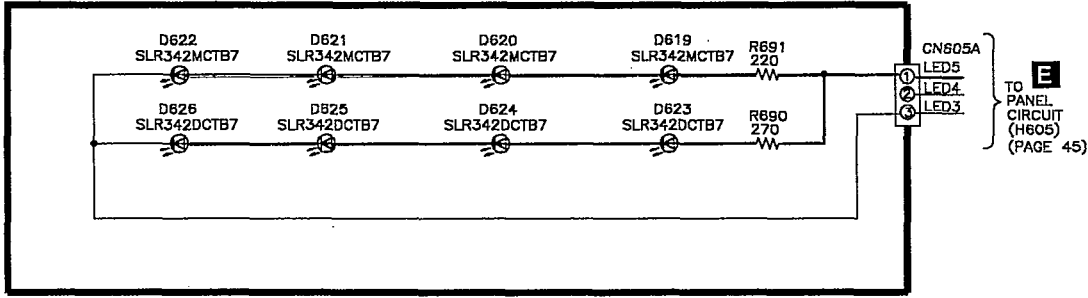

C DECK CIRCUIT

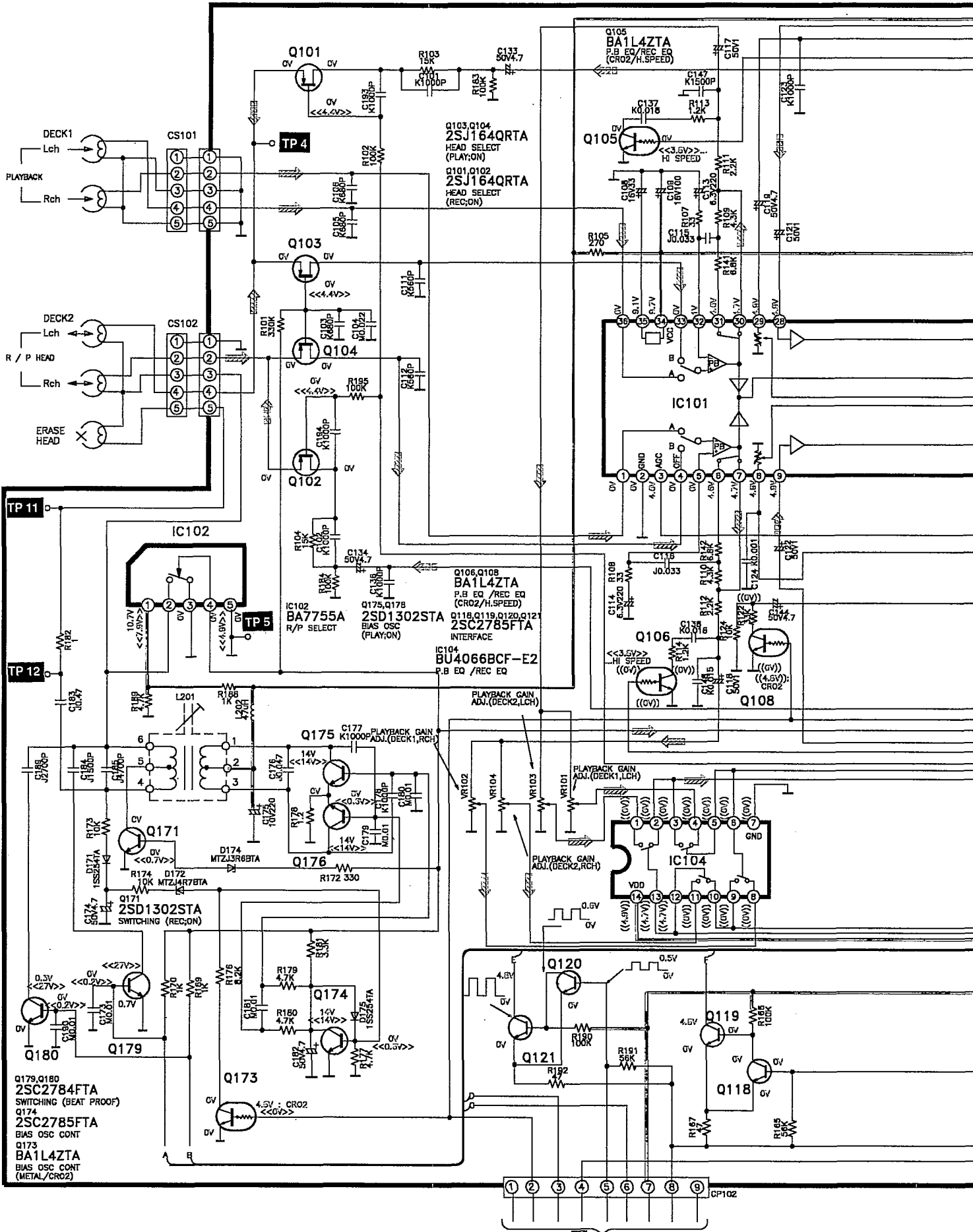

TO MECHANISM (DECK2) CIRCUIT (CS971) (PAGE 53)

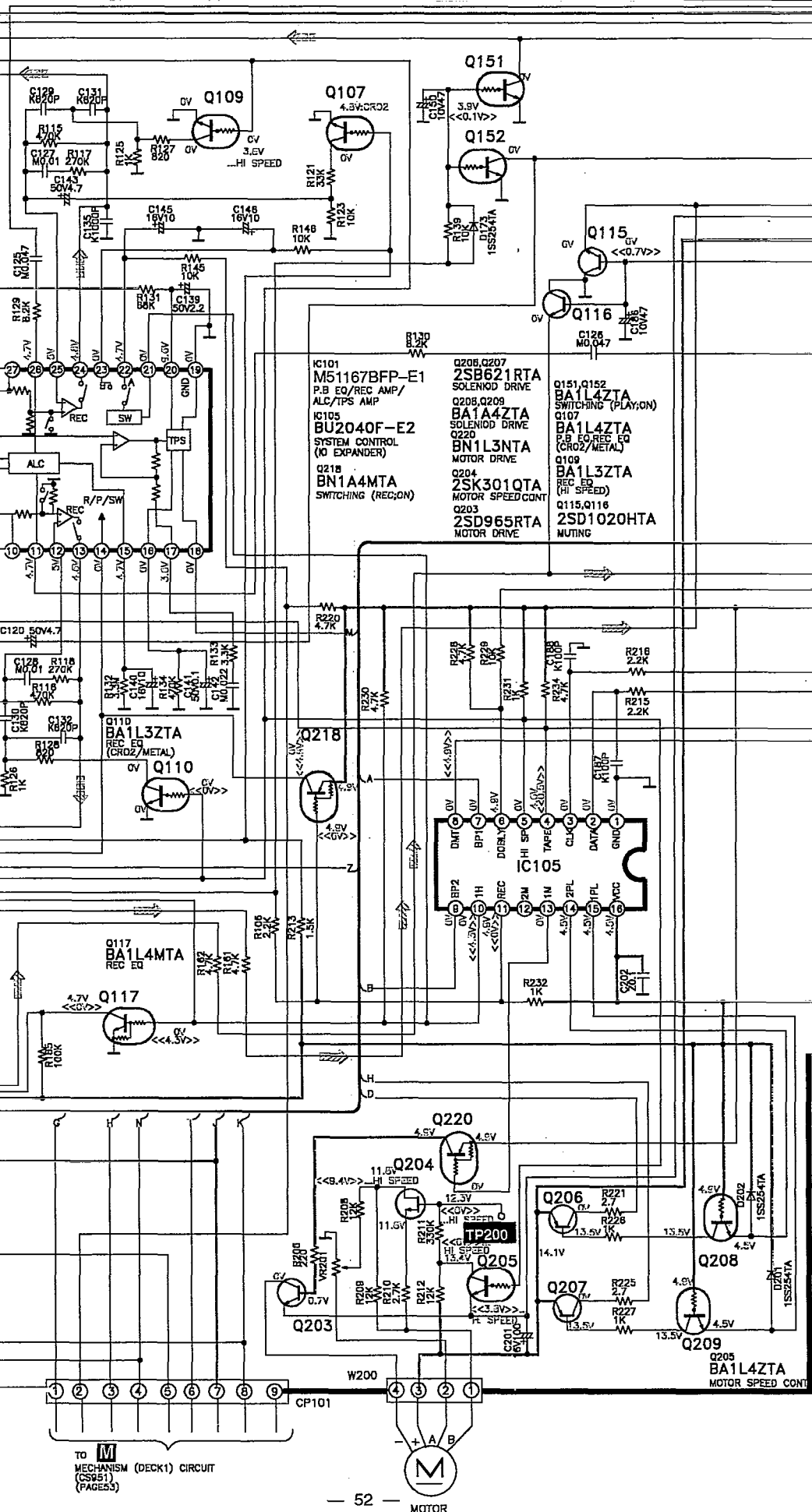

TO MECHANISM (DECK1) CIRCUIT (CS951) (PAGE53)

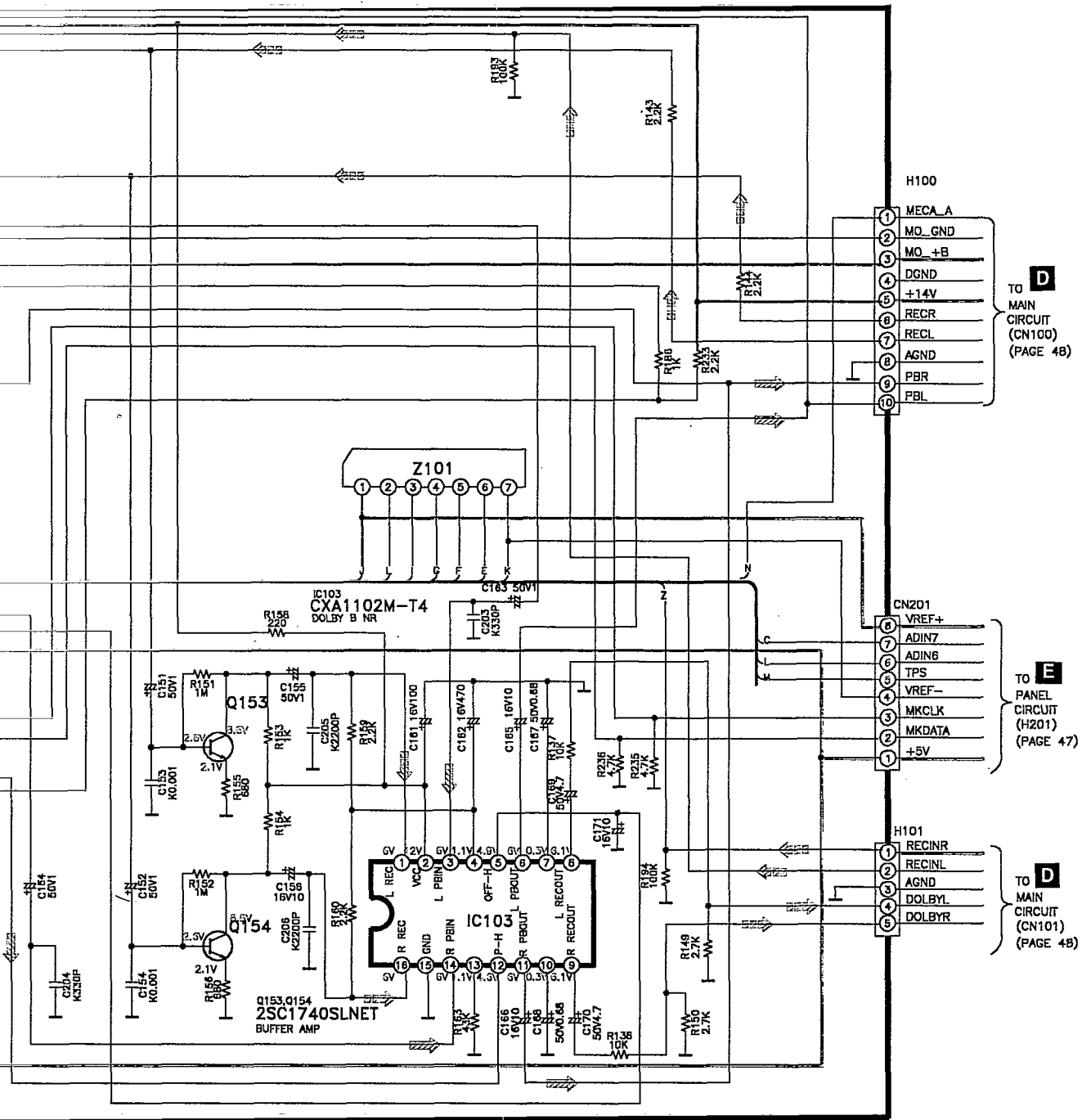

M MECHANISM (DECK 1) CIRCUIT

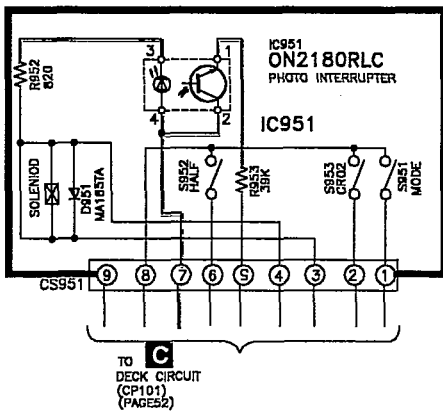

N MECHANISM (DECK 2) CIRCUIT

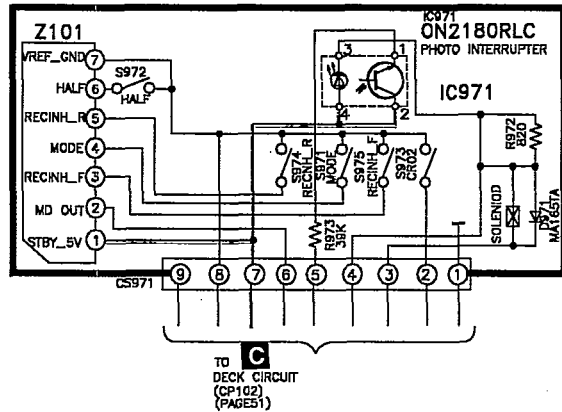

K POWER CIRCUIT

D
TO MAIN
CIRCUIT
(CP503)
(PAGE 50)

D
TO MAIN
CIRCUIT
(CP503)
(PAGE 50)

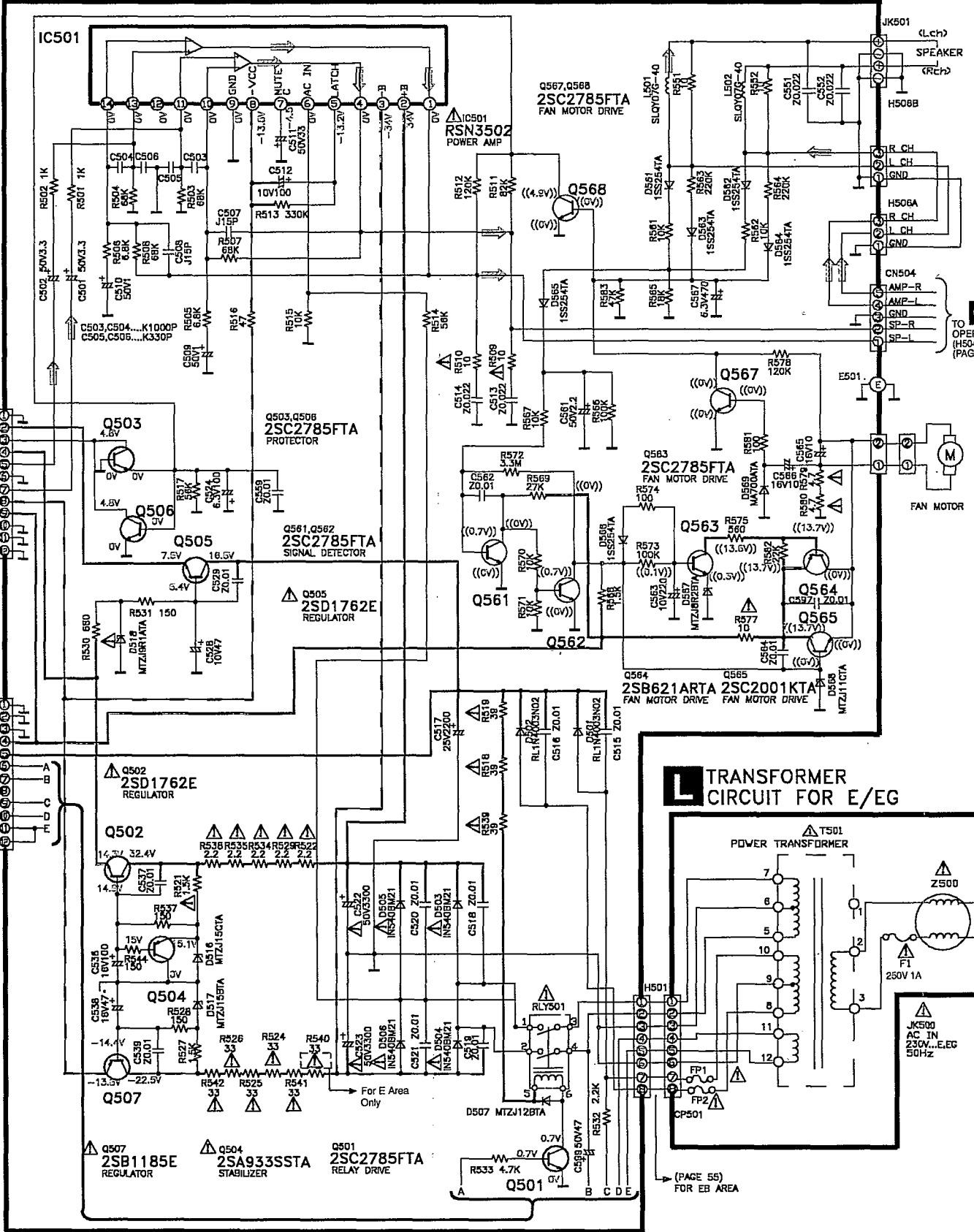

L TRANSFORMER
CIRCUIT FOR E/EG

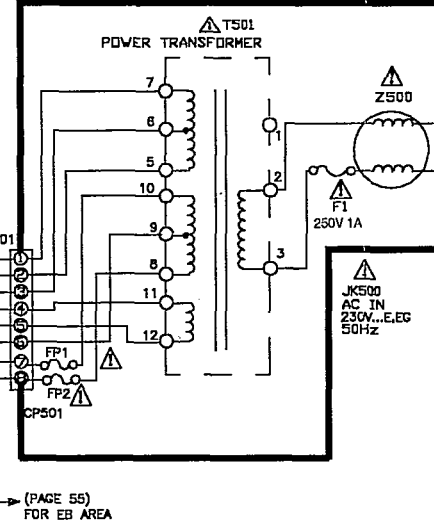

DETECTING SWITCH (1) CIRCUIT DETECTING SWITCH (2) CIRCUIT

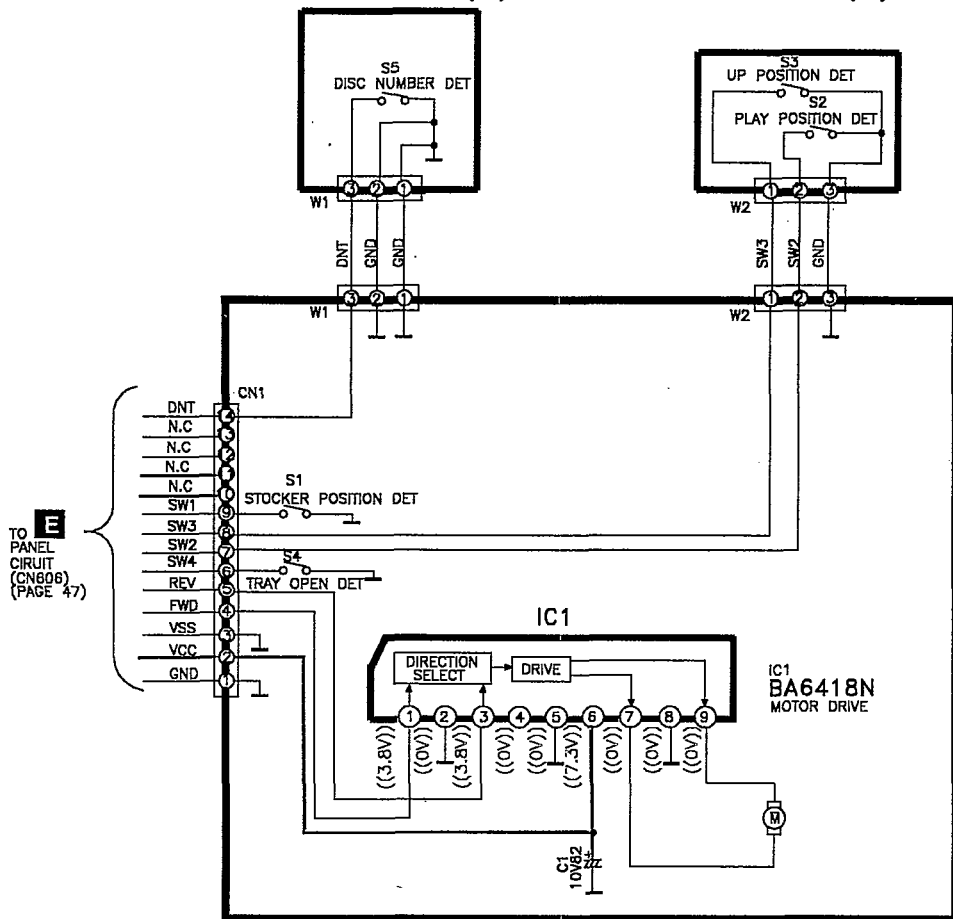

E
TO PANEL
CIRCUIT
(CN606)
(PAGE 47)

O LOADING MOTOR CIRCUIT

L TRANSFORMER
CIRCUIT FOR EB

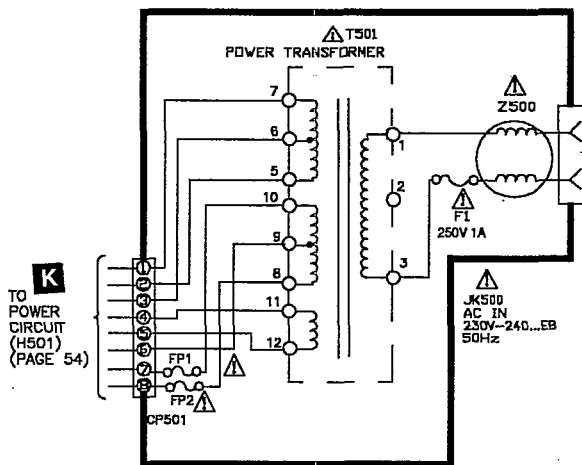

K
TO POWER
CIRCUIT
(H501)
(PAGE 54)

Troubleshooting Guide

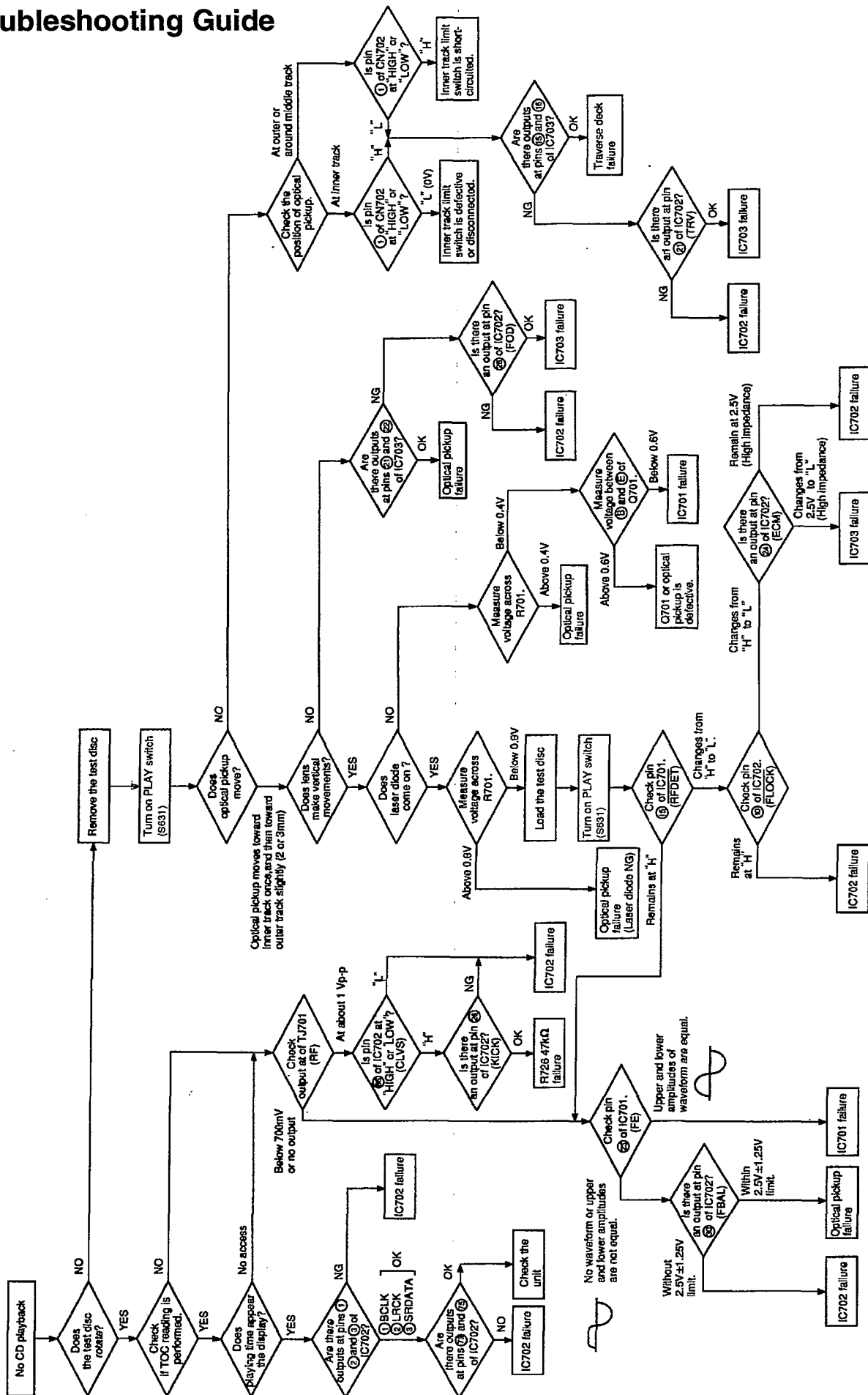

■ Mechanism Parts List

| Ref No. | Part No. | Part Name & Description | Remarks | Ref No. | Part No. | Part Name & Description | Remarks | Ref No. | Part No. | Part Name & Description | Remarks |
|---------|-----------|-------------------------|---------|---------|-----------|-------------------------|---------|---------|-------------|-------------------------|---------|
| | | CASSETTE DECK | | 113 | RMB0404 | SPRING | | 129 | RMK0283 | PLATE | |
| | | | | 114 | RMB0406 | SPRING | | 130 | RXL0124 | PINCH ROLLER ASS'Y | |
| 101 | RED0038 | P/B HEAD BLOCK ASS'Y | | 115 | RMB0408 | SPRING | | 130-1 | RMB0401 | SPRING | |
| 101-1 | RHE5152ZB | SCREW | | 116 | RML0370 | LEVER | | 131 | RXL0125 | PINCH ROLLER ASS'Y | |
| 102 | RED0037 | R/P HEAD BLOCK ASS'Y | | 117 | RML0371 | LEVER | | 131-1 | RMB0402 | SPRING | |
| 102-1 | RHE5152ZB | SCREW | | 118 | RML0372 | ARM | | 132 | RXL0126 | GEAR | |
| 103 | RDG0300 | REEL TABLE BASE | | 119 | RML0374 | LEVER | | 133 | RXQ0412 | ROD | |
| 104 | RDG0301 | GEAR | | 120 | RMM0131 | LEVER | | 133-1 | RMB0405 | SPRING | |
| 105 | RDK0026 | GEAR | | 121 | RMM0133 | LEVER | | 133-2 | RMM0132 | ROD | |
| 106 | RDR0029 | RELAY PULLY | | 122 | RMQ0519 | REEL TABLE HEAD | | 134 | REM0055 | MOTOR ASS'Y | |
| 107 | RDV0033-1 | BELT | | 123 | RMS0398-1 | SHAFT | | 135 | RHD26022 | SCREW | |
| 108 | RDV0034 | BELT | | 124 | RSJ0003 | PLUNGER | | 136 | XTW2+5L | SCREW | |
| 109 | RDV0035 | BELT | | 125 | RUS609ZC | SPRING | | 137 | XTW26+10S | SCREW | |
| 110 | RUW147ZA | SPRING | | 126 | RXF0049 | FLYWHEEL ASS'Y | | 138 | XYC2+JF17 | SCREW | |
| 111 | RMB0400 | REEL TABLE SPRING | | 127 | RXF0050 | FLYWHEEL ASS'Y | | 139 | RFKJXED70-K | CHASSIS ASS'Y | |
| 112 | RMB0403 | SPRING | | 128 | RXG0040 | GEAR | | | | | |

■ CD Loading Unit Parts List

Note : [M] mark in Remarks column indicates parts that are supplied by MESA.

| Ref No. | Part No. | Part Name & Description | Remarks | Ref No. | Part No. | Part Name & Description | Remarks | Ref No. | Part No. | Part Name & Description | Remarks |
|---------|--------------|--------------------------|---------|---------|--------------|-------------------------|---------|---------|--------------|-------------------------|---------|
| | | LOADING MECHANISM | | 321 | RMM0141 | SLIDE PLATE LEVER (2) | | 344-1 | RMF0221 | FELT | |
| | | | | 322 | RGQ0175-K | TRAY ORNAMENT | | 345 | RML0381 | HOLDING CATCH (1) | |
| 301 | RDG0309 | RELAY GEAR | [M] | 323 | RHD20010 | SCREW DRIVE RACK | [M] | 346 | RML0382 | HOLDING CATCH (2) | |
| 302 | RDG0310 | PULLEY GEAR | [M] | 324 | RMA0868 | SUPPORT ANGLE | [M] | 347 | RML0384 | UP PREVENTION LEVER | [M] |
| 303 | RDG0311 | DRIVE GEAR | [M] | 325 | RME0171 | BASE LOCK LEVER SP. | | 348 | RHM245ZA | MAGNET | [M] |
| 304 | RDG0313 | UP/DOWN GEAR LEVER | | 326 | RME0172 | CARRIER LOCK LEVER SP. | | 349 | RME0174 | CLAMP BASE SPRING | |
| 305 | RDV0036 | BELT | [M] | 327 | RML0377 | BASE LOCK LEVER | | 350 | RFKNACH430GE | CLAMP BASE ASS'Y | |
| 306 | RFKPD5790PK1 | MOTOR ASS'Y | [M] | 328 | RML0378 | CARRIER LOCK LEVER | | 351 | RML0388-1 | CLAMP LEVER | |
| 307 | RGQ0170-K | TRAY 1 | [M] | 329 | RMR0884-K | TRAY BASE | | 352 | RMR0761-W | MAGNET HOLDER LEVER | |
| 308 | RGQ0171-K | TRAY 2 | [M] | 330 | RHD20009-1 | SCREW CARRIER | | 353 | RMR0899-K | FIXED PLATE | |
| 309 | RGQ0172-K | TRAY 3 | [M] | 331 | RMC0274 | TRAY FOOK SPRING | [M] | 354 | XTB3+10JFZ | SCREW PB, LID | |
| 310 | RGQ0173-K | TRAY 4 | [M] | 332 | RME0173 | CARRIER ARMS SPRING | | 355 | RMR0975-W | TRV CAP | |
| 311 | RGQ0174-K | TRAY 5 | [M] | 333 | RML0376-1 | CARRIER ARM | | 358 | RAE0150Z | TRAVERSE UNIT | |
| 312 | RME0170 | LOCK LEVER SPRING | [M] | 334 | RMM0137 | CARRIER LEVER | | 358-1 | SHGD113-1 | FLOATING RUBBER | |
| 313 | RME0179 | ASSIST SPRING | [M] | 335 | RDG0312 | SPEED UP GEAR | [M] | 358-2 | SNSD38 | SCREW | |
| 314 | RME0180 | TRAY HOLDER SPRING | | 336 | RMM0134 | DRIVE RACK | [M] | 359 | RME0109 | FLOATING SPRING (1) | |
| 315 | RFKNACH430GC | MECHA BASE ASS'Y | | 337 | RMM0135 | CUSHION RACK | [M] | 360 | RME0142 | FLOATING SPRING (2) | |
| 315-1 | RMF0221 | FELT | | 338 | XTN2+6F | SCREWS SUPPORT ANGLE | [M] | 361 | RMK0293 | TRAVERSE CHASSIS | [M] |
| 315-2 | RMG0402-K | RUBBER WASHER | | 339 | XTS3+8J | SCREW | | 362 | RMS0123-1 | FIXED PIN | |
| 316 | RML0379 | CHANGE LEVER | [M] | 340 | XWE4E10 | CUSHION | | 363 | XTN2+6G | SCREW | |
| 317 | RML0380 | LOCK LEVER | [M] | 341 | RME0178 | HOLDING SPRING | | 364 | XTV2+6G | SCREW | |
| 318 | RML0383 | TRAY HOLDING LEVER | | 342 | RME0181 | UP PREVENTION SP (R) | [M] | 365 | REZ0792 | 3P WIRE KIT | |
| 319 | RML0385 | UP/DOWN LEVER | | 343 | RME0182 | UP PREVENTION SP (L) | [M] | 366 | REZ0793 | 3P WIRE KIT | |
| 320 | RMM0139 | SLIDE PLATE LEVER (1) | | 344 | RFKNACH430GD | MECHA COVER ASS'Y | | 367 | RMG0430-Q | RUBBER TUBE | |

■ Mechanism Parts Location (RAA3404)

DECK 2 (REC/PLAYBACK)

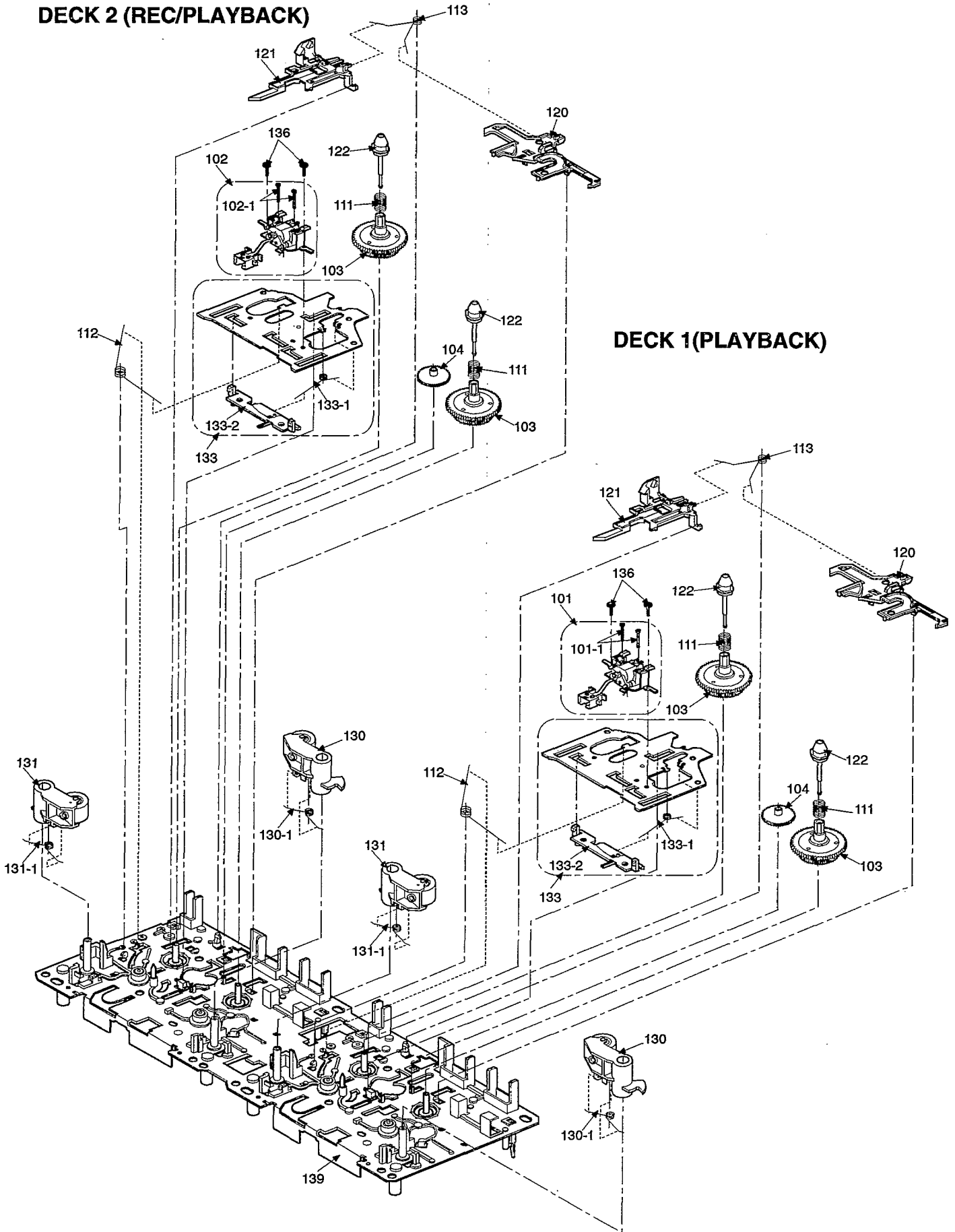

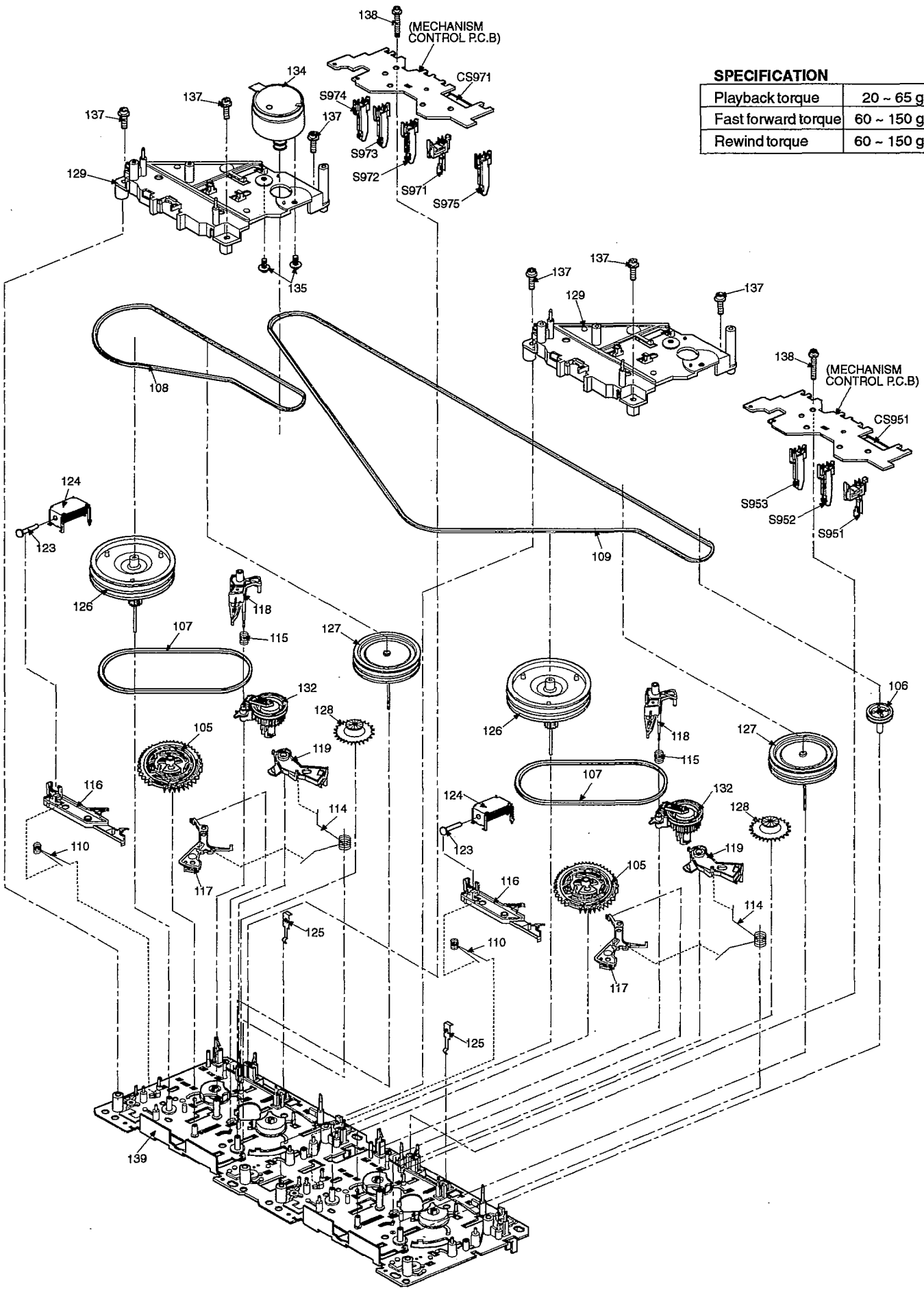

SPECIFICATION

| | |
|---------------------|---------------|
| Playback torque | 20 ~ 65 g•cm |
| Fast forward torque | 60 ~ 150 g•cm |
| Rewind torque | 60 ~ 150 g•cm |

Cabinet Parts Location

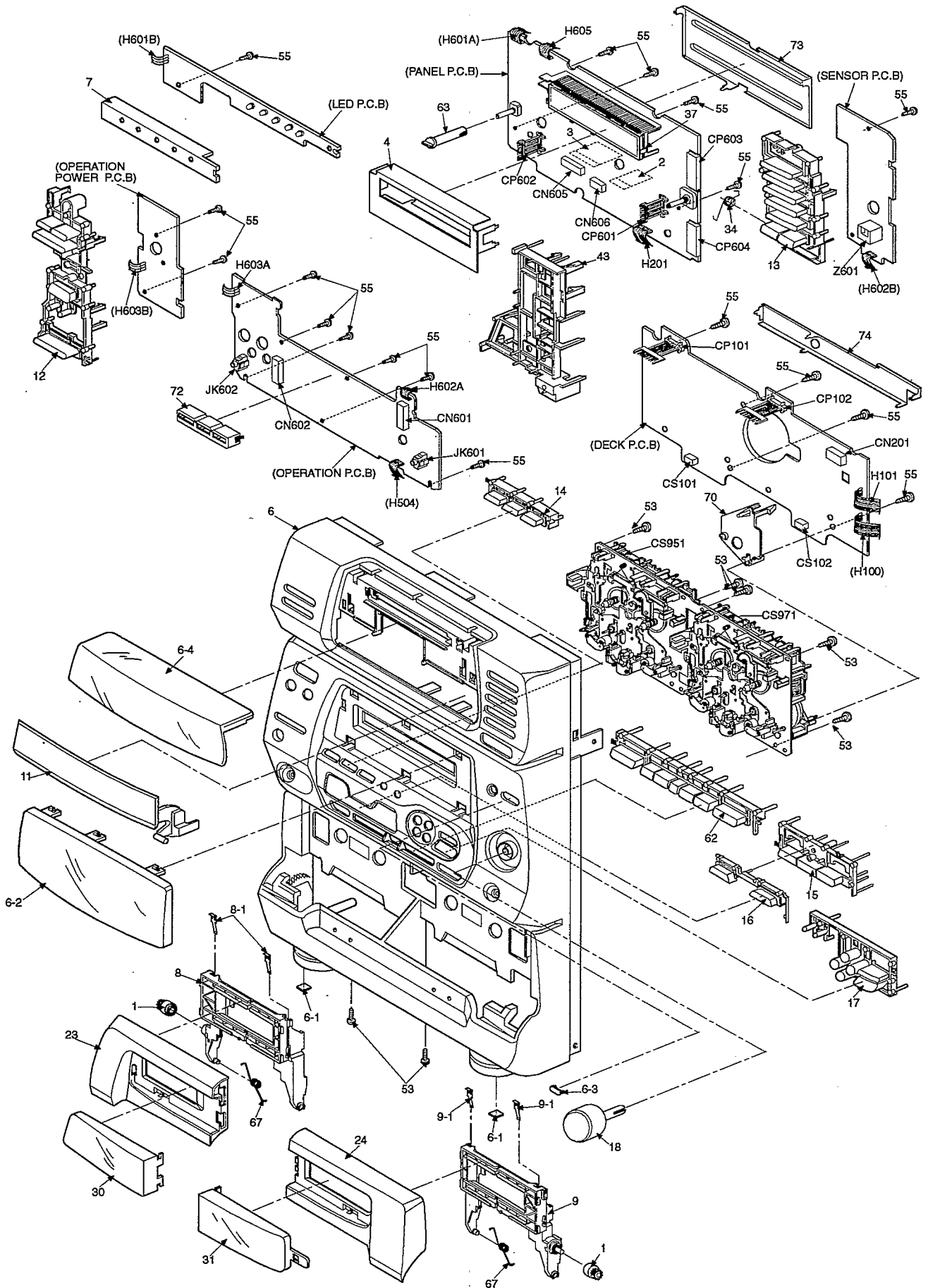

Cabinet Parts Location

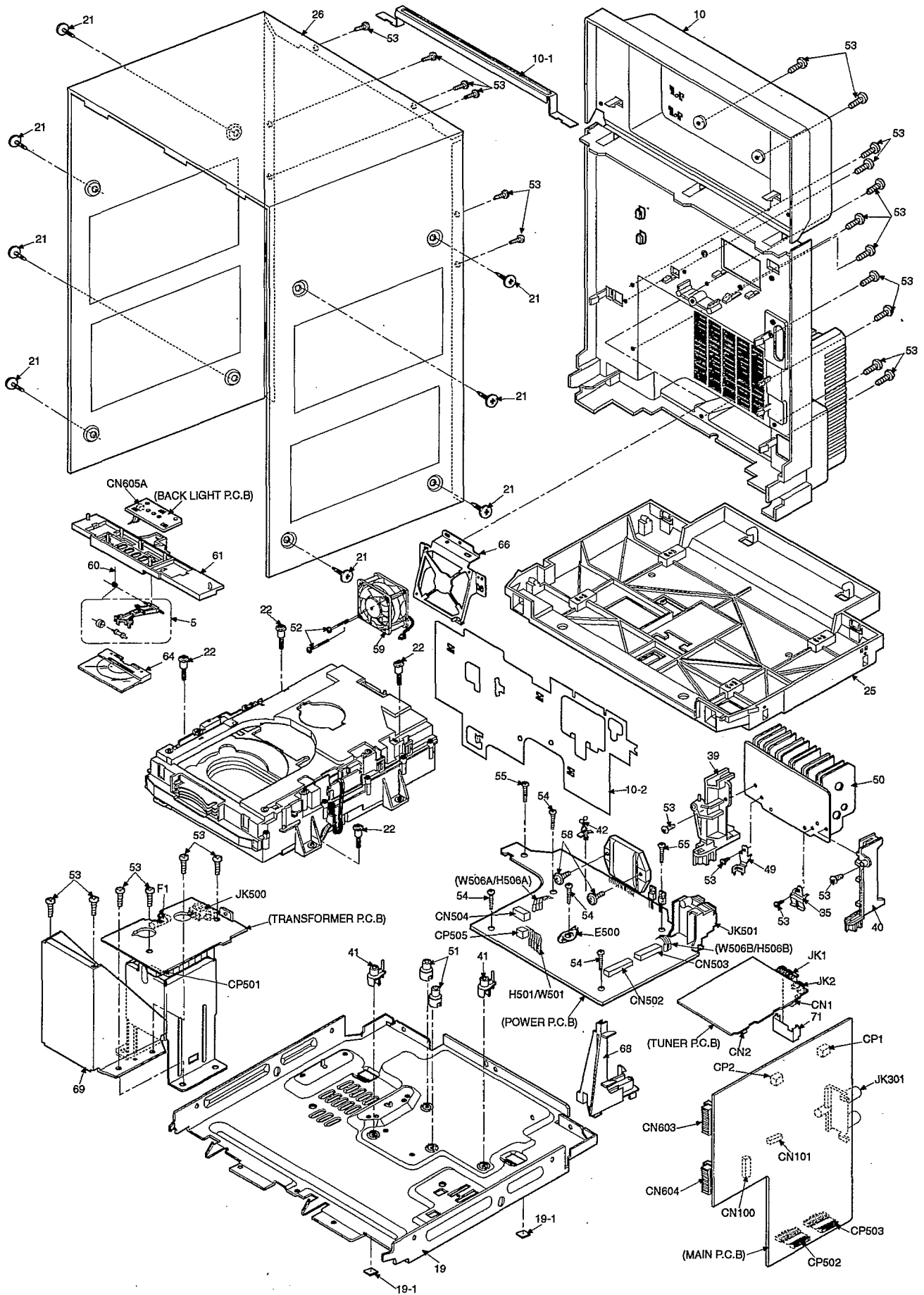

CD Loading Unit Parts Location

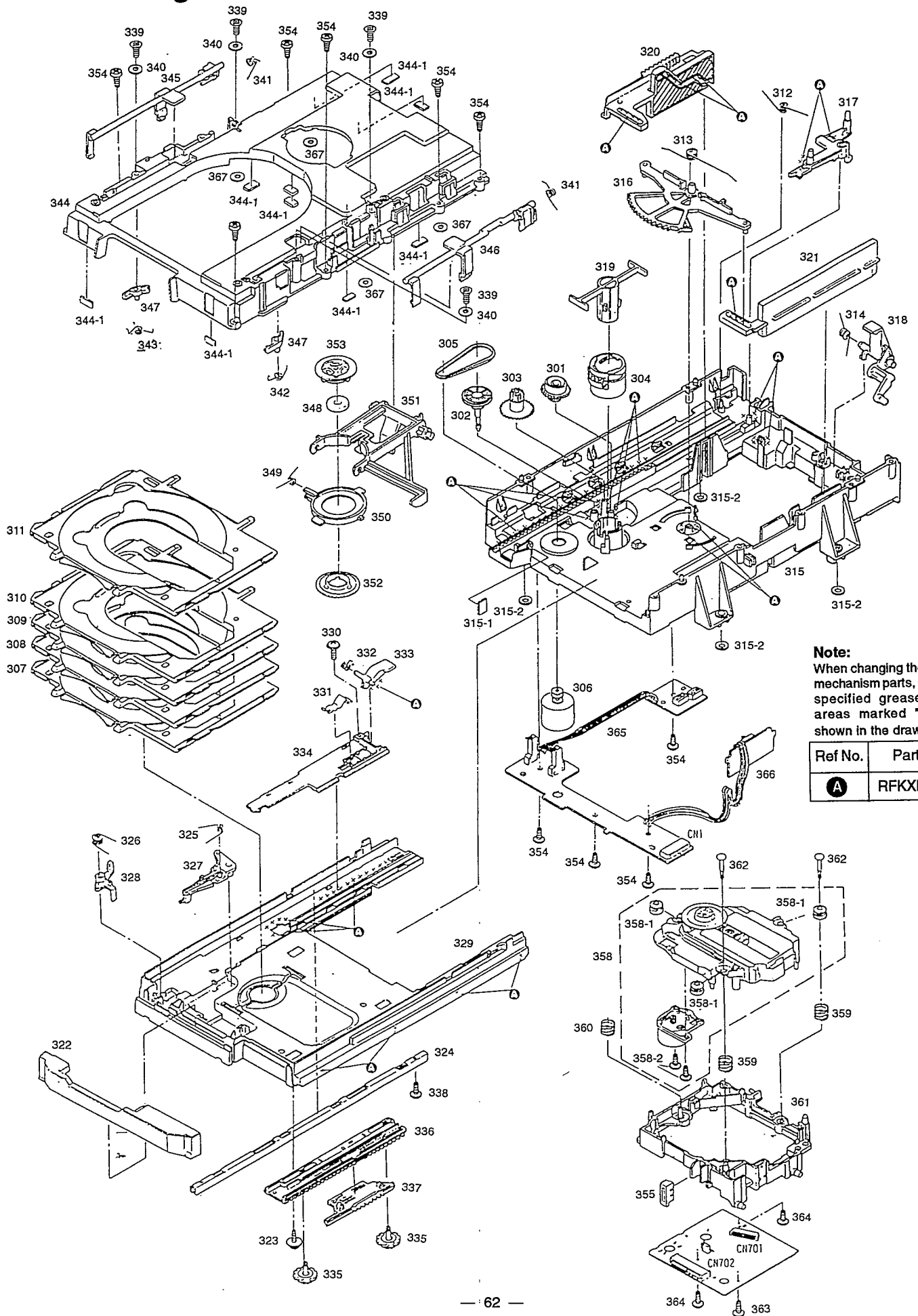

Note:
When changing the loading mechanism parts, apply the specified grease to the areas marked "xxx" as shown in the drawing.

| Ref No. | Part No. |
|---------|-----------|
| A | RFKXPG671 |

■ Replacement Parts List

Notes:

- Important safety notice :

Components identified by  mark have special characteristics important for safety.

Furthermore, special parts which have purposes of fire-retardant (resistors), high-quality sound (capacitors), low-noise (resistors), etc. are used. When replacing any of components, be sure to use only manufacturer's specified parts shown in the parts list.

- The parenthesized indications in the Remarks column specify the areas. (refer to the cover page for area.)

Parts without these indications can be used for all areas.

- [M] indicates in Remarks column parts that are supplied by MESA.

- **Warning:** This product uses a laser diode. Refer to caution statements on page 3.

ACHTUNG: • Die Lasereinheit nicht zerlegen.

• Die Lasereinheit darf nur gegen eine vom hersteller spezifizierte einheit ausgetauscht werden.

| Ref No. | Part No. | Part Name & Description | Remarks | Ref No. | Part No. | Part Name & Description | Remarks | Ref No. | Part No. | Part Name & Description | Remarks |
|---------|--------------|----------------------------|-----------|---------|--------------|----------------------------|---------|---------|--------------|-------------------------|---|
| | | CABINET AND CHASSIS | | | | | | | | | |
| 1 | RDG0129 | DAMPER GEAR | [M] | 35 | RMC0158-S | TR FIXTURE | [M] | IC301 | BU4052BCF-E2 | IC, ANALOG SWITCH | |
| 2 | REE0657 | 14P FFC | | 37 | RMN0352 | FL HOLDER | [M] | IC302 | M62422FPE1 | IC, IO EXPANDER | |
| 3 | REE0658 | 23P FFC | | 39 | RMR0653-K | HEAT SINK SUPPORT(L) | [M] | IC303 | M51131L-702 | IC, SOUND PROCESSOR | |
| 4 | RFKNACH330-K | FL SHIELD PLATE ASS'Y | [M] | 40 | RMR0654-K | HEAT SINK SUPPORT(R) | [M] | IC304 | BU2090F-E2 | IC, IO EXPANDER | [M] |
| 5 | RFKNACH34PK | HOLDER ARM ASS'Y | [M] | 41 | RMR0741-X | PCB SUPPORT (PIN) | [M] | IC305 | BA4558FDXE2 | IC, OP AMP | [M] |
| 6 | RFKGACH74EK | FRONT PANEL ASS'Y | [M] | 42 | RMR0824-W | WIRE CLAMPER | | IC306 | BA4558FDXE2 | IC, REC PLAYBACK | [M] |
| 6-1 | RKA0059-K | LEG RUBBER | [M] | 43 | RMR0908-X | PANEL PCB SUPPORT | [M] | IC308 | BU4066BCF-E2 | IC, SWITCH | [M] |
| 6-2 | RKW0416A-Q | FL WINDOW | [M] | 49 | RSC0362 | EARTH TERMINAL | [M] | IC401 | LM2940T5M | IC, AMP |  |
| 6-3 | RKW0414-Q | SENSOR WINDOW | [M] | 50 | RXX0102 | HEAT SINK UNIT | [M] | IC441 | BA4558FDXE2 | IC, OP AMP | [M] |
| 6-4 | RKW0415-Q | CHANGER WINDOW | [M] | 51 | SHE187-4 | PCB SUPPORT (NO PIN) | [M] | IC501 | RSN3502 | IC, HIC |  |
| 7 | RFKNACH430GB | 5-LED REFLECTOR ASS'Y | | 52 | XTB3+30J | FAN UNIT SCREW | | IC601 | M38197MA136F | IC, MICRO PROCESSOR | [M] |
| 8 | RFKLACH330AK | CASS HOLDER ASS'Y(L) | [M] | 53 | XTB3+10JFZ | REAR PANEL SCREW | | IC602 | TA2011S | IC, MIC AMP | |
| 8-1 | RUS757ZAA | CASS. HALF SPRING | [M] | 54 | XTB3+20J | POWER PCB SCREW | | IC605 | BU2090F-E2 | IC, IO EXPANDER | [M] |
| 9 | RFKLACH330BK | CASS HOLDER ASS'Y(R) | [M] | 55 | XTBS26+10J | PANEL PCB SCREW | | IC606 | BU2090F-E2 | IC, IO EXPANDER | [M] |
| 9-1 | RUS757ZAA | CASS. HALF SPRING | [M] | 58 | XTW3+15T | POWER IC SCREW | | IC608 | DAP803 | IC, DIODE ARRAY | |
| 10 | RFKHACH74EBK | REAR PANEL ASS'Y | [M](EB) | 59 | FBA08A12M2CZ | FAN UNIT | [M] | IC609 | DAP803 | IC, DIODE ARRAY | |
| 10 | RFKHACH74EK | REAR PANEL ASS'Y | [M](E,EG) | 60 | RME0221 | HOLDER ARM SPRING | [M] | IC951 | 0N2180RLC | IC, HALL | |
| 10-1 | RMA0938 | REAR SUPPORT ANGLE | [M] | 61 | RMN0350 | 8 LED HOLDER | [M] | IC971 | 0N2180RLC | IC, HALL | |
| 10-2 | RSC0449-1 | FTZ SHIELD | [M] | 62 | RGU1305-K | DECK BUTTON | [M] | | | TRANSISTORS | |
| 11 | RGK0767A-K | CHANGER LID | [M] | 63 | RGW0237-K | MIC KNOB | [M] | Q6 | 2SC2787LTA | TRANSISTOR | |
| 12 | RGU1303-K | POWER BUTTON | [M] | 64 | RKW0418-Q | 8 LED REFLECTOR | [M] | Q7 | RVTDTA143XST | TRANSISTOR | |
| 13 | RGU1304-K | DISK BUTTON | [M] | 66 | RMA0980 | FAN HOLDER | [M] | Q8 | 2SC1740SSTA | TRANSISTOR | |
| 14 | RGU1300-C | FUNCTION BUTTON | [M] | 67 | RMB0446 | CASS OPEN SPRING | [M] | Q9 | 2SC1740SSTA | TRANSISTOR | |
| 15 | RGU1301-K | CONTROL BUTTON (A) | [M] | 68 | RMR0821-X | MAIN PCB SUPPORT | [M] | Q10 | 2SC2785FETA | TRANSISTOR | |
| 16 | RGU1302-K | CONTROL BUTTON (B) | [M] | 69 | RSC0455 | TRANS. SHIELD PLATE | | Q11 | 2SC2785FETA | TRANSISTOR | |
| 17 | RGU1306A-K | EQ BUTTON | [M] | 70 | RMR0909-X | DECK PCB SUPPORT | [M] | Q12 | 2SC2787LTA | TRANSISTOR | |
| 18 | RGW0238-K | MAIN VOLUME KNOB | [M] | 71 | RSC0403 | TUNER SHIELD PLATE | [M] | Q13 | 2SC1740SSTA | TRANSISTOR | |
| 19 | RFKJACH430GK | BOTTOM CHASSIS ASS'Y | | 72 | RMN0348 | FUNCTION LED HOLDER | [M] | Q14 | 2SC1740SSTA | TRANSISTOR | |
| 19-1 | RKA0059-K | LEG RUBBER | [M] | 73 | RSC0447 | FL SHIELD PLATE(PCB) | [M] | Q15 | 2SC1740SSTA | TRANSISTOR | |
| 21 | RHD30007 | CABINET SCREW | | 74 | RSC0452-1 | DECK PCB SHIELD PLATE | [M] | Q101 | 2SJ164QRTA | TRANSISTOR | |
| 22 | RHD30048 | CD MECHANISM SCREW | [M] | | | INTEGRATED CIRCUITS | | | Q102 | 2SJ164QRTA | TRANSISTOR |
| 23 | RGK0765-K | CASSETTE LID (L) | [M] | IC1 | LA1832A | IC, DRIVER | | Q103 | 2SJ164QRTA | TRANSISTOR | |
| 24 | RGK0766-K | CASSETTE LID (R) | [M] | IC2 | LC7218 | IC, PLL | | Q104 | 2SJ164QRTA | TRANSISTOR | |
| 25 | RKM0309-K | CHANGER CHASSIS | [M] | IC101 | M51167BFP-E1 | IC, R/P | [M] | Q105 | BA1L4ZTA | TRANSISTOR | [M] |
| 26 | RKM0310A-K | CABINET | [M] | IC102 | BA7755A | IC, SW | [M] | Q106 | BA1L4ZTA | TRANSISTOR | [M] |
| 30 | RKW0412-Q | CASSETTE WINDOW (L) | [M] | IC103 | CXA1102M-T4 | IC, DOLBY | | Q107 | BA1L4ZTA | TRANSISTOR | [M] |
| 31 | RKW0413-Q | CASSETTE WINDOW (R) | [M] | IC104 | BU4066BCF-E2 | IC, ANALOG SWITCH | [M] | Q108 | BA1L4ZTA | TRANSISTOR | [M] |
| 34 | RMB0447 | CD LID SPRING | [M] | IC105 | BU2040F-E2 | IC, I/O | [M] | Q109 | BA1L3ZTA | TRANSISTOR | [M] |

| Ref No | Part No. | Part Name & Description | Remarks | Ref No | Part No. | Part Name & Description | Remarks | Ref No | Part No. | Part Name & Description | Remarks |
|--------|--------------|-------------------------|---------|--------|-------------|-------------------------|---------|--------|-------------|-------------------------|---------|
| Q110 | BA1L3ZTA | TRANSISTOR | [M] | Q453 | 2SD1762E | TRANSISTOR | [M]▲ | D415 | 1D3E | DIODE | [M] |
| Q115 | 2SD1020HTA | TRANSISTOR | [M] | Q501 | 2SC2785FTA | TRANSISTOR | | D416 | 1D3E | DIODE | [M] |
| Q116 | 2SD1020HTA | TRANSISTOR | [M] | Q502 | 2SD1762E | TRANSISTOR | [M]▲ | D417 | 1D3E | DIODE | [M] |
| Q117 | BA1L4MTA | TRANSISTOR | [M] | Q503 | 2SC2785FTA | TRANSISTOR | | D441 | 1SS254TA | DIODE | |
| Q118 | 2SC2785FTA | TRANSISTOR | | Q504 | 2SA933SSTA | TRANSISTOR | ▲ | D452 | MTZJ13ATA | DIODE | ▲ |
| Q119 | 2SC2785FTA | TRANSISTOR | | Q505 | 2SD1762E | TRANSISTOR | [M]▲ | D501 | RL1N4003N02 | DIODE | |
| Q120 | 2SC2785FTA | TRANSISTOR | | Q506 | 2SC2785FTA | TRANSISTOR | | D502 | RL1N4003N02 | DIODE | |
| Q121 | 2SC2785FTA | TRANSISTOR | | Q507 | 2SB1185E | TRANSISTOR | ▲ | D503 | 1N5402BM21 | DIODE | ▲ |
| Q151 | BA1L4ZTA | TRANSISTOR | [M] | Q561 | 2SC2785FTA | TRANSISTOR | | D504 | 1N5402BM21 | DIODE | ▲ |
| Q152 | BA1L4ZTA | TRANSISTOR | [M] | Q562 | 2SC2785FTA | TRANSISTOR | | D505 | 1N5402BM21 | DIODE | ▲ |
| Q153 | 2SC1740SLNET | TRANSISTOR | | Q563 | 2SC2785FTA | TRANSISTOR | | D506 | 1N5402BM21 | DIODE | ▲ |
| Q154 | 2SC1740SLNET | TRANSISTOR | | Q564 | 2SB621ARTA | TRANSISTOR | | D507 | MTZJ12BTA | DIODE | |
| Q171 | 2SD1302STA | TRANSISTOR | | Q565 | 2SC2001KTA | TRANSISTOR | | D516 | MTZJ15CTA | DIODE | |
| Q173 | BA1L4ZTA | TRANSISTOR | [M] | Q567 | 2SC2785FTA | TRANSISTOR | | D517 | MTZJ15BTA | DIODE | [M] |
| Q174 | 2SC2785FTA | TRANSISTOR | | Q568 | 2SC2785FTA | TRANSISTOR | | D518 | MTZJ9R1ATA | DIODE | ▲ |
| Q175 | 2SD1302STA | TRANSISTOR | | Q601 | BA1L4MTA | TRANSISTOR | [M] | D561 | 1SS254TA | DIODE | |
| Q176 | 2SD1302STA | TRANSISTOR | | Q602 | 2SC2785FTA | TRANSISTOR | | D562 | 1SS254TA | DIODE | |
| Q179 | 2SC2784FTA | TRANSISTOR | [M] | Q603 | 2SC2785FTA | TRANSISTOR | | D563 | 1SS254TA | DIODE | |
| Q180 | 2SC2784FTA | TRANSISTOR | [M] | Q604 | 2SB621RTA | TRANSISTOR | | D564 | 1SS254TA | DIODE | |
| Q203 | 2SD965RTA | TRANSISTOR | | Q612 | 2SC2785FTA | TRANSISTOR | | D565 | 1SS254TA | DIODE | |
| Q204 | 2SK301QTA | TRANSISTOR | [M] | Q613 | BN1A4MTA | TRANSISTOR | [M] | D566 | 1SS254TA | DIODE | |
| Q205 | BA1L4ZTA | TRANSISTOR | [M] | | | | | D567 | MTZJ8R2BTA | DIODE | [M] |
| Q206 | 2SB621RTA | TRANSISTOR | | | | DIODES | | D568 | MTZJ11CTA | DIODE | |
| Q207 | 2SB621RTA | TRANSISTOR | | | | | | D569 | MA700ATA | DIODE | |
| Q208 | BA1A4ZTA | TRANSISTOR | [M] | D4 | MTZJ5R1CTA | DIODE | [M] | D570 | 1SS254TA | DIODE | |
| Q209 | BA1A4ZTA | TRANSISTOR | [M] | D5 | RVD1SS133TA | DIODE | | D571 | MTZJ20BTA | DIODE | [M] |
| Q218 | BN1A4MTA | TRANSISTOR | [M] | D171 | 1SS254TA | DIODE | | D601 | 1SS291TA | DIODE | |
| Q220 | BN1L3NTA | TRANSISTOR | [M] | D172 | MTZJ4R7BTA | DIODE | | D602 | 1SS291TA | DIODE | |
| Q301 | 2SK301QTA | TRANSISTOR | [M] | D173 | 1SS254TA | DIODE | | D603 | 1SS254TA | DIODE | |
| Q302 | 2SK301QTA | TRANSISTOR | [M] | D174 | MTZJ3R6BTA | DIODE | [M] | D604 | 1SS254TA | DIODE | |
| Q303 | 2SC2785FTA | TRANSISTOR | | D175 | 1SS254TA | DIODE | | D605 | MA167TA | DIODE | |
| Q304 | 2SC2785FTA | TRANSISTOR | | D201 | 1SS254TA | DIODE | | D609 | MTZJ5R6BTA | DIODE | |
| Q305 | 2SD1450STA | TRANSISTOR | | D202 | 1SS254TA | DIODE | | D611 | MA167TA | DIODE | |
| Q306 | 2SD1450STA | TRANSISTOR | | D301 | MTZJ6R8CTA | DIODE | | D613 | MA167TA | DIODE | |
| Q307 | 2SD1450STA | TRANSISTOR | | D303 | 1SS254TA | DIODE | | D616 | 1SS254TA | DIODE | |
| Q308 | BN1A4MTA | TRANSISTOR | [M] | D304 | 1SS254TA | DIODE | | D617 | 1SS254TA | DIODE | |
| Q309 | BN1A4MTA | TRANSISTOR | [M] | D308 | 1SS254TA | DIODE | | D618 | 1SS254TA | DIODE | |
| Q311 | BN1A4MTA | TRANSISTOR | [M] | D401 | 1SS254TA | DIODE | | D619 | SLR342MCTB7 | DIODE | |
| Q401 | BA1L3ZTA | TRANSISTOR | [M] | D402 | 1SS254TA | DIODE | | D620 | SLR342MCTB7 | DIODE | |
| Q402 | 2SC2001KTA | TRANSISTOR | ▲ | D403 | MTZJ7R5CTA | DIODE | ▲ | D621 | SLR342MCTB7 | DIODE | |
| Q403 | 2SD2037ETA | TRANSISTOR | [M]▲ | D404 | MTZJ6R8BTA | DIODE | ▲ | D622 | SLR342MCTB7 | DIODE | |
| Q404 | 2SD2037ETA | TRANSISTOR | [M]▲ | D405 | 1SS254TA | DIODE | | D623 | SLR342DCTB7 | DIODE | |
| Q405 | BA1F4MTA | TRANSISTOR | [M] | D406 | 1SS254TA | DIODE | | D624 | SLR342DCTB7 | DIODE | |
| Q406 | 2SB621ARTA | TRANSISTOR | ▲ | D407 | MA167TA | DIODE | | D625 | SLR342DCTB7 | DIODE | |
| Q407 | 2SC2785FTA | TRANSISTOR | | D408 | 1D3E | DIODE | [M] | D626 | SLR342DCTB7 | DIODE | |
| Q409 | 2SB621ARTA | TRANSISTOR | | D409 | 1D3E | DIODE | [M] | D627 | SLR-325MC | DIODE | |
| Q410 | 2SC2785FTA | TRANSISTOR | ▲ | D410 | MTZJ33CTA | DIODE | [M] | D628 | SLR-325MC | DIODE | |
| Q451 | 2SD1762E | TRANSISTOR | [M]▲ | D413 | MTZJ5R6BTA | DIODE | ▲ | D629 | SLR-325MC | DIODE | |

| RefNo. | PartNo. | Part Name & Description | Remarks | RefNo. | PartNo. | Part Name & Description | Remarks | RefNo. | Part No. | Part Name & Description | Remarks |
|--------|--------------|---------------------------|---------|--------|-------------|-------------------------|---------|--------|--------------|---------------------------------|---------|
| D630 | SLR-325MC | DIODE | | S615 | EVQ21405R | SW, EQ SPACE RIGHT | | CN604 | RJU077K20 | CONNECTOR (20P) | [M] |
| D631 | SLR-325MC | DIODE | | S616 | EVQ21405R | SW, KARAOKE | | CN605 | RJS1A6223-1 | CONNECTOR (23P) | |
| D632 | SLR-325MC | DIODE | | S617 | EVQ21405R | SW, REW/DOWN | | CN605A | RJS1A5203 | SOCKET (3P) | |
| D633 | SLR-325MC | DIODE | | S618 | EVQ21405R | SW, FF/UP | | CN606 | RJS1A6214-1 | CONNECTOR (14P) | |
| D634 | SLR325DCT31 | DIODE | | S620 | EVQ21405R | SW, STOP | | CP1 | RJT063W07T | CONNECTOR (7 P) | |
| D635 | SLR325DCT31 | DIODE | | S621 | EVQ21405R | SW, REV PLAY | | CP2 | RJT063W07T | CONNECTOR (7 P) | |
| D636 | SLR-325MC | DIODE | | S622 | EVQ21405R | SW, FWD PLAY | | CP101 | RJT071H09A | CONNECTOR (9 P) | |
| D637 | SLR325DCT31 | DIODE | | S623 | EVQ21405R | SW, EJECT DECK 1 | | CP102 | RJT071H09A | CONNECTOR (9 P) | |
| D638 | SLR325DCT31 | DIODE | | S624 | EVQ21405R | SW, TAPE EDIT NORMAL | | CP501 | RJP8G18ZA | CONNECTOR (8P) | |
| D639 | SLR-325MC | DIODE | | S625 | EVQ21405R | SW, TAPE EDIT HIGH | | CP502 | RJT005W012 | CONNECTOR (12P) | |
| D640 | SLR325DCT31 | DIODE | | S626 | EVQ21405R | SW, REC | | CP503 | RJT005W012 | CONNECTOR (12P) | |
| D641 | SLR325DCT31 | DIODE | | S627 | EVQ21405R | SW, REV MODE | | CP505 | RJP2G4YA | CONNECTOR (2P) | |
| D642 | SPR505MDTT | DIODE | | S628 | EVQ21405R | SW, EJECT DECK 2 | | CP601 | RJT071H09A | CONNECTOR (9 P) | |
| D643 | SPR505MDTT | DIODE | | S629 | EVQ21405R | SW, DOLBY NR | | CP602 | RJT071H09A | CONNECTOR (9 P) | |
| D644 | SPR505MDTT | DIODE | | S631 | EVQ21405R | SW, CD OPEN/CLOSE | | CP603 | RJT077K20 | CONNECTOR (20P) | [M] |
| D645 | SPR505MDTT | DIODE | | S632 | EVQ21405R | SW, CD DISC CHECK | | CP604 | RJT077K20 | CONNECTOR (20P) | [M] |
| D646 | SPR505MDTT | DIODE | | S633 | EVQ21405R | SW, DISC 5 | | CS101 | RJS1A6805-J | CONNECTOR SOCKET(5P) | [M] |
| D647 | 1SS254TA | DIODE | | S634 | EVQ21405R | SW, DISC 4 | | CS102 | RJS1A6805-J | CONNECTOR SOCKET(5P) | [M] |
| D651 | SLR-325MC | DIODE | | S635 | EVQ21405R | SW, DISC 3 | | GS951 | RJU071H09M1 | 9P CONNECTOR | [M] |
| D652 | SLR-325MC | DIODE | | S636 | EVQ21405R | SW, DISC 2 | | GS971 | RJU071H09M1 | 9P CONNECTOR | [M] |
| D659 | 1SS254TA | DIODE | | S637 | EVQ21405R | SW, DISC 1 | | | | | |
| D951 | MA165TA | DIODE | | S638 | EVQ21405R | SW, DISPLAY/DEMO | | | | COILS & TRANSFORMERS | |
| D971 | MA165TA | DIODE | | S639 | EVQ21405R | SW, AUX | | | | | |
| | | | | S640 | EVQ21405R | SW, TUNER | | L3 | RLQZPR47KT-Y | COIL | |
| | | VARIABLE RESISTORS | | S641 | EVQ21405R | SW, CD | | L4 | ELEPKR68MA | RF CHOKE COIL | |
| | | | | S642 | EVQ21405R | SW, DECK 1/2 | | L5 | ELEPKR68MA | RF CHOKE COIL | |
| VR101 | RRN6B05B24TA | VR, SEMIFIXED | | S951 | RSH1A018-1U | SW, MODE DETECT(1) | | L6 | ELELN822KL | RF CHOCK COIL | |
| VR102 | RRN6B05B24TA | VR, SEMIFIXED | | S952 | RSH1A019-2U | SW, TAPE DETECT(1) | | L7 | ELELN822KL | RF CHOCK COIL | |
| VR103 | RRN6B05B24TA | VR, SEMIFIXED | | S953 | RSH1A019-2U | SW, Cr02 DETECT(1) | | L8 | RLQZP1R0KT-Y | AXIAL COIL | |
| VR104 | RRN6B05B24TA | VR, SEMIFIXED | | S971 | RSH1A018-1U | SW, MODE DETECT(2) | | L9 | SLM1B10-1M | A.B. FILTER | |
| VR201 | RRN6B05B73TA | VR, SEMIFIXED | | S972 | RSH1A019-2U | SW, TAPE DETECT(2) | | L201 | RL08C002M-T | BIAS OSC COIL | |
| VR601 | RRV09A03B14A | VR, MIC | | S973 | RSH1A019-2U | SW, Cr02 DETECT(2) | | L202 | RLQZB470KT-D | RF CHOKE COIL | |
| VR603 | RRV16B24104B | VR, VOLUME | [M] | S974 | RSH1A019-2U | SW, REC DETECT(2) | | L501 | SLQY07G-40 | SP COIL | |
| | | | | S975 | RSH1A019-2U | SW, REC DETECT(2) | | L502 | SLQY07G-40 | SP COIL | |
| | | SWITCHES | | | | | | L601 | RLQZP3R3KT-Y | COIL | |
| | | | | | | CONNECTORS | | T501 | RTP2M3B003 | POWER TRANSFORMER | [M] ⚠ |
| S601 | EVQ21405R | SW, POWER | | | | | | | | COMPONENT COMBINATION | |
| S602 | EVQ21405R | SW, TIMER PLAY | | CN1 | RJU063W07T | CONNECTOR (20P) | | Z1 | RLA6Z005M-T | AM ANT/OSC | |
| S603 | EVQ21405R | SW, TIMER REC | | CN2 | RJU063W07T | CONNECTOR (20P) | | Z2 | RLI2Z006M-T | AM IFT | |
| S604 | EVQ21405R | SW, RANDOM | | CN100 | RJS1A5210 | CONNECTOR (10P) | [M] | Z3 | ENV17290G1R | FM TUNER PACK | |
| S605 | EVQ21405R | SW, REPEAT | | CN101 | RJS1A5205 | CONNECTOR (5P) | [M] | Z101 | EXBF7L355SYV | RADA RESISTOR | |
| S606 | EVQ21405R | SW, EASY EDIT | | CN201 | RJS8T7ZA | CONNECTOR (8P) | | Z500 | SLQZ650MH49 | AC LINE COIL | ⚠ |
| S608 | EVQ21405R | SW, CLOCK/TIMER | | CN502 | RJU005A012 | CONNECTOR (12P) | | Z601 | RCDHC-278N | REMO-CON SENSOR | [M] |
| S609 | EVQ21405R | SW, EQ. SPACE | | CN503 | RJU005A012 | CONNECTOR (12P) | | | | | |
| S611 | EVQ21405R | SW, V. BASS | | CN504 | RJS1A5205 | CONNECTOR (5P) | [M] | | | CERAMIC FILTERS | |
| S612 | EVQ21405R | SW, EQ SPACE DOWN | | CN601 | RJU071H09M | CONNECTOR (9 P) | | CF1 | RLFFETNGA01L | FM CF | |
| S613 | EVQ21405R | SW, EQ SPACE UP | | CN602 | RJU071H09M | CONNECTOR (9 P) | | CF2 | RLFFETNGA02L | FM CF | |
| S614 | EVQ21405R | SW, EQ SPACE LEFT | | CN603 | RJU077K20 | CONNECTOR (20P) | [M] | | | | |

| Ref.No. | Part.No. | Part.Name & Description | Remarks | Ref.No. | Part.No. | Part.Name & Description | Remarks | Ref.No. | Part.No. | Part.Name & Description | Remarks | |
|-----------------------------------|--------------|-------------------------|---------|----------------|-------------|--------------------------|---------|-------------------------------|--------------|-------------------------|---------|--|
| OSCILLATORS | | | | JACKS | | | | S2 | RSH1A032-U | SW, MECHA | | |
| X1 | RSXZ456KM01 | 19KHZ OSC | | JK1 | RJH8201 | JK, ANTENNA TERMINAL | [M] | S3 | RSH1A032-U | SW, MECHA | | |
| X2 | RLFDF12DD | FM RESONATOR | | JK2 | SJS208 | JK, AM LOOP ANT TERMINAL | | S4 | RSH1A005 | SW, LEAF | | |
| X3 | SVQ49U722T-S | 7.2MHZ X'TAL | | JK301 | RJH3209N | JK, LINE-IN | [M] | S5 | RSH1A032-U | SW, MECHA | | |
| X601 | RSXD32K7S02 | 32.768HKZ X'TAL | [M] | JK500 | SJS9236 | JK, AC INLET | ⚠ | CONNECTOR | | | | |
| X602 | EF0EN6004T4 | CERAMIC OSC | [M] | JK501 | RJR0054 | JK, SP TERMINAL | | CN1 | RJS1A6714 | 14P CONNECTOR | | |
| DISPLAY TUBE | | | | JK601 | RJJ37TK04-C | JK, HP JACK | | < SERVO P.C.B. > | | | | |
| FL601 | RSL0211-F | FL | [M] | JK602 | RJJ34MK01-C | JK, MIC JACK | | INTEGRATED CIRCUITS | | | | |
| EARTH TERMINAL | | | | HOLDERS | | | | IC701 | AN8835SBE1 | IC, SERVO AMP. | | |
| E500 | SNE1004-2 | EARTH TERMINAL | | H100 | RMR0319 | 10P CABLE HOLDER | [M] | IC702 | MN862741RPA | IC, DIGITAL LSI | | |
| RELAY | | | | H101 | RMR0314 | 5P CABLE HOLDER | [M] | IC703 | AN8389SE1 | IC, COIL/MOTOR DRIVE | | |
| RLY501 | RSY0017-0 | RELAY | [M] ⚠ | H201 | RMR0317 | 8P CABLE HOLDER | [M] | TRANSISTOR | | | | |
| FUSES | | | | H501 | RMR0317 | 8P CABLE HOLDER | [M] | Q701 | 2SB709S | TRANSISTOR | | |
| F1 | XBA2C10TB0 | FUSE | ⚠ | H504 | RMR0314 | 5P CABLE HOLDER | [M] | SWITCH | | | | |
| FUSE CLIPS | | | | H601A | RMR0314 | 5P CABLE HOLDER | [M] | S701 | RSM0006-P | SW, RESET | | |
| FC1 | SJT388 | FUSE CLIP | | H602A | RMR0315 | 6P CABLE HOLDER | [M] | CONNECTORS | | | | |
| FC2 | SJT388 | FUSE CLIP | | H603A | RMR0312 | 3P CONNECTOR | [M] | CN701 | RJU035T016-1 | 16 PIN FFC CONNECTOR | | |
| FUSE PROTECTORS | | | | H605 | RMR0312 | 3P CONNECTOR | [M] | CN702 | RJS1A6723-1Q | 23 PIN FFC CONNECTOR | | |
| FP1 | RSFMB40KT-L | FUSE PROTECTOR | ⚠ | WIRE | | | | OSCILLATOR | | | | |
| FP2 | RSFMB40KT-L | FUSE PROTECTOR | ⚠ | W501 | REX0773 | WIRE | [M] | X701 | RSXZ16M9M01T | CERAMIC OSC | | |
| RESISTORS & CAPACITORS | | | | WIRE | | | | LOADING MOTOR | | | | |
| RESISTORS | | | | WIRE | | | | INTEGRATED CIRCUIT | | | | |
| R15 | ERDS2TJ181T | 180 1/4W | | IC1 | BA6418N | IC, MOTOR DRIVER | | SWITCHES | | | | |
| R16 | ERDS2TJ153T | 15K 1/4W | | S1 | RSH1A005 | SW, LEAF | | SWITCHES | | | | |
| R17 | ERDS2TJ331T | 330 1/4W | | | | | | | | | | |
| R18 | ERDS2TJ471T | 470 1/4W | | | | | | | | | | |
| R19 | ERDS2TJ474T | 470K 1/4W | | | | | | | | | | |

Resistors & Capacitors



Notes : • Important safety notice:

Components identified by ⚠ mark have special characteristics important for safety.

Furthermore, special parts which have purposes of fire-retardant (resistors), high-quality sound (capacitors), low-noise (resistors), etc. are used. When replacing any of components, be sure to use only manufacturer's specified parts shown in the parts list.

- [M] indicates in Remarks column parts that are supplied by MESA.
- Capacitor values are in microfarad (μF) unless specified otherwise, P=Pico-farads (pF) F=Farads (F)
- Resistors values are in ohms, unless specified otherwise, 1k=1,000(OHM), 1M=1,000k(OHM)

| Ref.No. | Part.No. | Values & Remarks | Ref.No. | Part.No. | Values & Remarks | Ref.No. | Part.No. | Values & Remarks | Ref.No. | Part.No. | Values & Remarks |
|------------------|-------------|------------------|---------|-------------|------------------|---------|-------------|------------------|---------|-------------|------------------|
| RESISTORS | | | R20 | ERDS2TJ562T | 5.6K 1/4W | R27 | ERDS2TJ272T | 2.7K 1/4W | R36 | ERDS2TJ474T | 470K 1/4W |
| | | | R21 | ERDS2TJ822T | 8.2K 1/4W | R28 | ERDS2TJ473T | 47K 1/4W | R37 | ERDS2TJ474T | 470K 1/4W |
| R15 | ERDS2TJ181T | 180 1/4W | R22 | ERDS2TJ473T | 47K 1/4W | R29 | ERDS2TJ680T | 68 1/4W | R38 | ERDS2TJ272T | 2.7K 1/4W |
| R16 | ERDS2TJ153T | 15K 1/4W | R23 | ERDS2TJ332T | 3.3K 1/4W | R32 | ERDS2TJ272T | 2.7K 1/4W | R39 | ERDS2TJ272T | 2.7K 1/4W |
| R17 | ERDS2TJ331T | 330 1/4W | R24 | ERDS2TJ472T | 4.7K 1/4W | R33 | ERDS2TJ272T | 2.7K 1/4W | R40 | ERDS2TJ391T | 390 1/4W |
| R18 | ERDS2TJ471T | 470 1/4W | R25 | ERDS2TJ271T | 270 1/4W | R34 | ERDS2TJ103T | 10K 1/4W | R41 | ERDS2TJ102T | 1K 1/4W |
| R19 | ERDS2TJ474T | 470K 1/4W | R26 | ERDS2TJ471T | 470 1/4W | R35 | ERDS2TJ103T | 10K 1/4W | R42 | ERDS2TJ102T | 1K 1/4W |

| RefNo. | PartNo. | Values & Remarks | RefNo. | PartNo. | Values & Remarks | RefNo. | PartNo. | Values & Remarks | RefNo. | PartNo. | Values & Remarks |
|--------|-------------|------------------|--------|-------------|------------------|--------|-------------|------------------|--------|--------------|---|
| R43 | ERDS2TJ102T | 1K 1/4W | R123 | ERDS2TJ103T | 10K 1/4W | R181 | ERDS2TJ332T | 3.3K 1/4W | R312 | ERDS2TJ392T | 3.9K 1/4W |
| R44 | ERDS2TJ102T | 1K 1/4W | R124 | ERDS2TJ103T | 10K 1/4W | R182 | ERDS2TJ1R0T | 1 1/4W | R313 | ERDS2TJ562T | 5.6K 1/4W |
| R45 | ERDS2TJ102T | 1K 1/4W | R125 | ERDS2TJ102T | 1K 1/4W | R183 | ERDS2TJ104T | 100K 1/4W | R314 | ERDS2TJ562T | 5.6K 1/4W |
| R46 | ERDS2TJ104T | 100K 1/4W | R126 | ERDS2TJ102T | 1K 1/4W | R184 | ERDS2TJ104T | 100K 1/4W | R315 | ERDS2TJ332T | 3.3K 1/4W |
| R47 | ERDS2TJ562T | 5.6K 1/4W | R127 | ERDS2TJ821T | 820 1/4W | R185 | ERDS2TJ104T | 100K 1/4W | R316 | ERDS2TJ332T | 3.3K 1/4W |
| R48 | ERDS2TJ391T | 390 1/4W | R128 | ERDS2TJ821T | 820 1/4W | R186 | ERDS2TJ102T | 1K 1/4W | R317 | ERDS2TJ104T | 100K 1/4W |
| R49 | ERDS2TJ561T | 560 1/4W | R129 | ERDS2TJ822T | 8.2K 1/4W | R188 | ERDS2TJ102T | 1K 1/4W | R318 | ERDS2TJ104T | 100K 1/4W |
| R50 | ERDS2TJ102T | 1K 1/4W | R130 | ERDS2TJ822T | 8.2K 1/4W | R189 | ERDS2TJ472T | 4.7K 1/4W | R319 | ERDS2TJ103T | 10K 1/4W |
| R51 | ERDS2TJ103T | 10K 1/4W | R131 | ERDS2TJ683T | 68K 1/4W | R190 | ERDS2TJ104T | 100K 1/4W | R320 | ERDS2TJ474T | 470K 1/4W |
| R52 | ERDS2TJ102T | 1K 1/4W | R132 | ERDS2TJ335T | 3.3M 1/4W | R191 | ERDS2TJ563T | 56K 1/4W | R321 | ERDS2TJ332T | 3.3K 1/4W |
| R53 | ERDS2TJ102T | 1K 1/4W | R133 | ERDS2TJ332T | 3.3K 1/4W | R192 | ERDS2TJ470T | 47 1/4W | R322 | ERDS2TJ332T | 3.3K 1/4W |
| R54 | ERDS2TJ102T | 1K 1/4W | R134 | ERDS2TJ474T | 470K 1/4W | R193 | ERDS2TJ104T | 100K 1/4W | R323 | ERDS2TJ102T | 1K 1/4W |
| R55 | ERDS2TJ102T | 1K 1/4W | R137 | ERDS2TJ103T | 10K 1/4W | R194 | ERDS2TJ104T | 100K 1/4W | R324 | ERDS2TJ102T | 1K 1/4W |
| R56 | ERDS2TJ102T | 1K 1/4W | R138 | ERDS2TJ103T | 10K 1/4W | R195 | ERDS2TJ104T | 100K 1/4W | R325 | ERDS2TJ563T | 56K 1/4W |
| R57 | ERDS2TJ103T | 10K 1/4W | R139 | ERDS2TJ103T | 10K 1/4W | R206 | ERDS2TJ221T | 220 1/4W | R326 | ERDS2TJ563T | 56K 1/4W |
| R58 | ERDS2TJ103T | 10K 1/4W | R141 | ERDS2TJ682T | 6.8K 1/4W | R208 | ERDS2TJ123T | 12K 1/4W | R327 | ERDS2TJ472T | 4.7K 1/4W |
| R60 | ERDS2TJ563T | 56K 1/4W | R142 | ERDS2TJ682T | 6.8K 1/4W | R209 | ERDS2TJ123T | 12K 1/4W | R328 | ERDS2TJ472T | 4.7K 1/4W |
| R61 | ERDS2TJ102T | 1K 1/4W | R143 | ERDS2TJ222T | 2.2K 1/4W | R210 | ERDS2TJ272T | 2.7K 1/4W | R329 | ERDS2TJ681T | 680 1/4W |
| R63 | ERDS2TJ102T | 1K 1/4W | R144 | ERDS2TJ222T | 2.2K 1/4W | R211 | ERDS2TJ334T | 330K 1/4W | R330 | ERDS2TJ681T | 680 1/4W |
| R64 | ERDS2TJ820T | 82 1/4W | R145 | ERDS2TJ103T | 10K 1/4W | R212 | ERDS2TJ123T | 12K 1/4W | R331 | ERDS2TJ152T | 1.5K 1/4W |
| R65 | ERDS2TJ103T | 10K 1/4W | R146 | ERDS2TJ103T | 10K 1/4W | R213 | ERDS2TJ152T | 1.5K 1/4W | R332 | ERDS2TJ472T | 4.7K 1/4W |
| R71 | ERDS2TJ182T | 1.8K 1/4W | R149 | ERDS2TJ272T | 2.7K 1/4W | R215 | ERDS2TJ222T | 2.2K 1/4W | R333 | ERDS2TJ122T | 1.2K 1/4W |
| R72 | ERDS2TJ122T | 1.2K 1/4W | R150 | ERDS2TJ272T | 2.7K 1/4W | R216 | ERDS2TJ222T | 2.2K 1/4W | R334 | ERDS2TJ122T | 1.2K 1/4W |
| R73 | ERDS2TJ122T | 1.2K 1/4W | R151 | ERDS2TJ105T | 1M 1/4W | R220 | ERDS2TJ472T | 4.7K 1/4W | R335 | ERDS2TJ563T | 56K 1/4W |
| R74 | ERDS2TJ103T | 10K 1/4W | R152 | ERDS2TJ105T | 1M 1/4W | R221 | ERDS2TJ2R7T | 2.7 1/4W | R336 | ERDS2TJ563T | 56K 1/4W |
| R75 | ERDS2TJ222T | 2.2K 1/4W | R153 | ERDS2TJ102T | 1K 1/4W | R225 | ERDS2TJ2R7T | 2.7 1/4W | R337 | ERDS2TJ272T | 2.7K 1/4W |
| R76 | ERDS2TJ331T | 330 1/4W | R154 | ERDS2TJ102T | 1K 1/4W | R226 | ERDS2TJ102T | 1K 1/4W | R338 | ERDS2TJ272T | 2.7K 1/4W |
| R77 | ERDS2TJ474T | 470K 1/4W | R155 | ERDS2TJ681T | 680 1/4W | R227 | ERDS2TJ102T | 1K 1/4W | R339 | ERDS1FVJ820T | 82 1/2W  |
| R101 | ERDS2TJ334T | 330K 1/4W | R156 | ERDS2TJ681T | 680 1/4W | R228 | ERDS2TJ472T | 4.7K 1/4W | R340 | ERDS1FVJ820T | 82 1/2W  |
| R102 | ERDS2TJ104T | 100K 1/4W | R158 | ERDS2TJ221T | 220 1/4W | R229 | ERDS2TJ103T | 10K 1/4W | R341 | ERDS2TJ472T | 4.7K 1/4W |
| R103 | ERDS2TJ153T | 15K 1/4W | R159 | ERDS2TJ222T | 2.2K 1/4W | R230 | ERDS2TJ472T | 4.7K 1/4W | R342 | ERDS2TJ472T | 4.7K 1/4W |
| R104 | ERDS2TJ153T | 15K 1/4W | R160 | ERDS2TJ222T | 2.2K 1/4W | R231 | ERDS2TJ102T | 1K 1/4W | R343 | ERDS2TJ182T | 1.8K 1/4W |
| R105 | ERDS2TJ271T | 270 1/4W | R161 | ERDS2TJ472T | 4.7K 1/4W | R232 | ERDS2TJ102T | 1K 1/4W | R344 | ERDS2TJ182T | 1.8K 1/4W |
| R106 | ERDS2TJ222T | 2.2K 1/4W | R162 | ERDS2TJ472T | 4.7K 1/4W | R233 | ERDS2TJ222T | 2.2K 1/4W | R345 | ERDS2TJ152T | 1.5K 1/4W |
| R107 | ERDS2TJ330T | 33 1/4W | R163 | ERDS2TJ433T | 43K 1/4W | R234 | ERDS2TJ472T | 4.7K 1/4W | R346 | ERDS2TJ152T | 1.5K 1/4W |
| R108 | ERDS2TJ330T | 33 1/4W | R165 | ERDS2TJ563T | 56K 1/4W | R235 | ERDS2TJ472T | 4.7K 1/4W | R347 | ERDS2TJ102T | 1K 1/4W |
| R109 | ERDS2TJ432T | 4.3K 1/4W | R166 | ERDS2TJ104T | 100K 1/4W | R236 | ERDS2TJ472T | 4.7K 1/4W | R348 | ERDS2TJ102T | 1K 1/4W |
| R110 | ERDS2TJ432T | 4.3K 1/4W | R167 | ERDS2TJ470T | 47 1/4W | R301 | ERDS2TJ223T | 22K 1/4W | R349 | ERDS2TJ104T | 100K 1/4W |
| R111 | ERDS2TJ222T | 2.2K 1/4W | R169 | ERDS2TJ102T | 1K 1/4W | R302 | ERDS2TJ223T | 22K 1/4W | R350 | ERDS2TJ104T | 100K 1/4W |
| R112 | ERDS2TJ222T | 2.2K 1/4W | R170 | ERDS2TJ102T | 1K 1/4W | R303 | ERDS2TJ822T | 8.2K 1/4W | R351 | ERDS2TJ473T | 47K 1/4W |
| R113 | ERDS2TJ122T | 1.2K 1/4W | R172 | ERDS2TJ331T | 330 1/4W | R304 | ERDS2TJ822T | 8.2K 1/4W | R352 | ERDS2TJ474T | 470K 1/4W |
| R114 | ERDS2TJ122T | 1.2K 1/4W | R173 | ERDS2TJ103T | 10K 1/4W | R305 | ERDS2TJ222T | 2.2K 1/4W | R353 | ERDS2TJ105T | 1M 1/4W |
| R115 | ERDS2TJ474T | 470K 1/4W | R174 | ERDS2TJ103T | 10K 1/4W | R306 | ERDS2TJ222T | 2.2K 1/4W | R354 | ERDS2TJ153T | 15K 1/4W |
| R116 | ERDS2TJ474T | 470K 1/4W | R176 | ERDS2TJ822T | 8.2K 1/4W | R307 | ERDS2TJ332T | 3.3K 1/4W | R355 | ERDS2TJ182T | 1.8K 1/4W |
| R117 | ERDS2TJ274T | 270K 1/4W | R177 | ERDS2TJ472T | 4.7K 1/4W | R308 | ERDS2TJ332T | 3.3K 1/4W | R356 | ERDS2TJ334T | 330K 1/4W |
| R118 | ERDS2TJ274T | 270K 1/4W | R178 | ERDS2TJ1R2T | 1.2 1/4W | R309 | ERDS2TJ222T | 2.2K 1/4W | R357 | ERDS2TJ105T | 1M 1/4W |
| R121 | ERDS2TJ333T | 33K 1/4W | R179 | ERDS2TJ472T | 4.7K 1/4W | R310 | ERDS2TJ222T | 2.2K 1/4W | R358 | ERDS2TJ222T | 2.2K 1/4W |
| R122 | ERDS2TJ333T | 33K 1/4W | R180 | ERDS2TJ472T | 4.7K 1/4W | R311 | ERDS2TJ392T | 3.9K 1/4W | R359 | ERDS2TJ682T | 6.8K 1/4W |

| Ref No | Part No. | Values & Remarks | Ref No | Part No. | Values & Remarks | Ref No | Part No. | Values & Remarks | Ref No | Part No. | Values & Remarks |
|--------|--------------|-------------------|--------|--------------|---------------------|--------|--------------|-------------------|--------|-------------|------------------|
| R360 | ERDS2TJ103T | 10K 1/4W | R445 | ERDS2TJ333T | 33K 1/4W | R540 | ERDS2TJ330T | 33 1/4W(E) | R627 | ERDS2TJ104T | 100K 1/4W |
| R383 | ERDS2TJ224T | 220K 1/4W | R446 | ERDS2TJ102T | 1K 1/4W | R541 | ERDS1FVJ330T | 33 1/2W Δ | R628 | ERDS2TJ104T | 100K 1/4W |
| R384 | ERDS2TJ224T | 220K 1/4W | R447 | ERDS2TJ182T | 1.8K 1/4W | R542 | ERDS1FVJ330T | 33 1/2W Δ | R629 | ERDS2TJ104T | 100K 1/4W |
| R386 | ERDS2TJ102T | 1K 1/4W | R452 | ERDS2TJ471T | 470 1/4W | R544 | ERDS2TJ151T | 150 1/4W | R630 | ERDS2TJ104T | 100K 1/4W |
| R387 | ERDS2TJ102T | 1K 1/4W | R457 | ERDS2TJ1R0T | 1 1/4W | R551 | ERDS2TJ100T | 10 1/4W | R631 | ERDS2TJ104T | 100K 1/4W |
| R391 | ERDS2TJ102T | 1K 1/4W | R458 | ERDS2TJ1R0T | 1 1/4W | R552 | ERDS2TJ100T | 10 1/4W | R632 | ERDS2TJ104T | 100K 1/4W |
| R392 | ERDS2TJ392T | 3.9K 1/4W | R491 | ERDS2TJ222T | 2.2K 1/4W | R561 | ERDS2TJ103T | 10K 1/4W | R633 | ERDS2TJ104T | 100K 1/4W |
| R393 | ERDS2TJ102T | 1K 1/4W | R492 | ERDS2TJ222T | 2.2K 1/4W | R562 | ERDS2TJ103T | 10K 1/4W | R634 | ERDS2TJ104T | 100K 1/4W |
| R394 | ERDS2TJ153T | 15K 1/4W | R493 | ERDS2TJ474T | 470K 1/4W | R563 | ERDS2TJ224T | 220K 1/4W | R635 | ERDS2TJ223T | 22K 1/4W |
| R397 | ERDS2TJ222T | 2.2K 1/4W | R494 | ERDS2TJ474T | 470K 1/4W | R564 | ERDS2TJ224T | 220K 1/4W | R636 | ERDS2TJ331T | 330 1/4W |
| R399 | ERDS2TJ472T | 4.7K 1/4W | R495 | ERDS2TJ474T | 470K 1/4W | R565 | ERDS2TJ183T | 18K 1/4W | R638 | ERDS2TJ103T | 10K 1/4W |
| R401 | ERDS2TJ103T | 10K 1/4W | R501 | ERDS2TJ102T | 1K 1/4W | R566 | ERDS2TJ104T | 100K 1/4W | R639 | ERDS2TJ103T | 10K 1/4W |
| R402 | ERDS2TJ333T | 33K 1/4W | R502 | ERDS2TJ102T | 1K 1/4W | R567 | ERDS2TJ103T | 10K 1/4W | R640 | ERDS2TJ103T | 10K 1/4W |
| R403 | ERDS2TJ223T | 22K 1/4W | R503 | ERDS2TJ683T | 68K 1/4W | R568 | ERDS2TJ152T | 1.5K 1/4W | R641 | ERDS2TJ103T | 10K 1/4W |
| R404 | ERDS2TJ120T | 12 1/4W | R504 | ERDS2TJ683T | 68K 1/4W | R569 | ERDS2TJ273T | 27K 1/4W | R642 | ERDS2TJ473T | 47K 1/4W |
| R405 | ERDS2TJ120T | 12 1/4W | R505 | ERDS2TJ682T | 6.8K 1/4W | R570 | ERDS2TJ103T | 10K 1/4W | R643 | ERDS2TJ473T | 47K 1/4W |
| R406 | ERDS2TJ120T | 12 1/4W | R506 | ERDS2TJ682T | 6.8K 1/4W | R571 | ERDS2TJ103T | 10K 1/4W | R644 | ERDS2TJ101T | 100 1/4W |
| R407 | ERDS2TJ331T | 330 1/4W | R507 | ERDS2TJ683T | 68K 1/4W | R572 | ERDS2TJ335T | 3.3M 1/4W | R645 | ERDS2TJ101T | 100 1/4W |
| R408 | ERDS2TJ151T | 150 1/4W | R508 | ERDS2TJ683T | 68K 1/4W | R573 | ERDS2TJ104T | 100K 1/4W | R646 | ERDS2TJ101T | 100 1/4W |
| R409 | ERDS2TJ221T | 220 1/4W | R509 | ERDS1FVJ100T | 10 1/2W Δ | R574 | ERDS2TJ101T | 100 1/4W | R647 | ERDS2TJ101T | 100 1/4W |
| R410 | ERDS1FVJ390T | 39 1/2W Δ | R510 | ERDS1FVJ100T | 10 1/2W Δ | R575 | ERDS2TJ561T | 560 1/4W | R648 | ERDS2TJ471T | 470 1/4W |
| R411 | ERDS1FVJ390T | 39 1/2W Δ | R511 | ERDS2TJ823T | 82K 1/4W | R577 | ERDS1FVJ100T | 10 1/2W Δ | R668 | ERDS2TJ105T | 1M 1/4W |
| R412 | ERDS1FVJ390T | 39 1/2W Δ | R512 | ERDS2TJ124T | 120K 1/4W | R578 | ERDS2TJ124T | 120K 1/4W | R669 | ERDS2TJ151T | 150 1/4W |
| R413 | ERDS2TJ102T | 1K 1/4W | R513 | ERDS2TJ334T | 330K 1/4W | R579 | ERDS1FVJ4R7T | 4.7 1/2W Δ | R670 | ERDS2TJ222T | 2.2K 1/4W |
| R414 | ERDS2TJ151T | 150 1/4W | R514 | ERDS2TJ563T | 56K 1/4W | R580 | ERDS1FVJ4R7T | 4.7 1/2W Δ | R671 | ERDS2TJ471T | 470 1/4W |
| R415 | ERDS2TJ102T | 1K 1/4W | R515 | ERDS2TJ103T | 10K 1/4W | R581 | ERDS2TJ101T | 100 1/4W | R681 | ERDS2TJ272T | 2.7K 1/4W |
| R416 | ERDS2TJ183T | 18K 1/4W | R516 | ERD25FVJ470T | 47 1/4W | R582 | ERDS2TJ223T | 22K 1/4W | R682 | ERDS2TJ272T | 2.7K 1/4W |
| R417 | ERDS2TJ183T | 18K 1/4W | R517 | ERDS2TJ563T | 56K 1/4W | R583 | ERDS2TJ473T | 47K 1/4W | R683 | ERDS2TJ471T | 470 1/4W |
| R418 | ERDS1FVJ181T | 180 1/2W Δ | R518 | ERDS1FVJ390T | 39 1/2W Δ | R601 | ERDS2TJ103T | 10K 1/4W | R684 | ERDS2TJ471T | 470 1/4W |
| R419 | ERDS2TJ472T | 4.7K 1/4W | R519 | ERDS1FVJ390T | 39 1/2W Δ | R602 | ERDS2TJ222T | 2.2K 1/4W | R685 | ERDS2TJ223T | 22K 1/4W |
| R420 | ERDS1FVJ181T | 180 1/2W Δ | R521 | ERDS1FVJ152T | 1.5K 1/2W Δ | R603 | ERDS2TJ102T | 1K 1/4W | R686 | ERDS2TJ223T | 22K 1/4W |
| R421 | ERDS2TJ333T | 33K 1/4W | R522 | ERDS1FVJ2R2T | 2.2 1/2W Δ | R604 | ERDS2TJ561T | 560 1/4W | R687 | ERDS2TJ103T | 10K 1/4W |
| R422 | ERDS2TJ331T | 330 1/4W | R524 | ERDS1FVJ220T | 22 1/2W Δ | R605 | ERDS2TJ104T | 100K 1/4W | R690 | ERDS2TJ271T | 270 1/4W |
| R423 | ERDS2TJ223T | 22K 1/4W | R525 | ERDS1FVJ330T | 33 1/2W Δ | R606 | ERDS2TJ104T | 100K 1/4W | R691 | ERDS2TJ221T | 220 1/4W |
| R424 | ERDS2TJ331T | 330 1/4W | R526 | ERDS1FVJ330T | 33 1/2W Δ | R607 | ERDS2TJ103T | 10K 1/4W | R694 | ERDS2TJ182T | 1.8K 1/4W |
| R427 | ERDS2TJ103T | 10K 1/4W | R527 | ERDS2TJ152T | 1.5K 1/4W | R608 | ERDS2TJ103T | 10K 1/4W | R695 | ERDS2TJ222T | 2.2K 1/4W |
| R431 | ERDS2TJ391T | 390 1/4W | R528 | ERDS2TJ151T | 150 1/4W | R611 | ERDS2TJ473T | 47K 1/4W | R696 | ERDS2TJ272T | 2.7K 1/4W |
| R432 | ERDS2TJ391T | 390 1/4W | R529 | ERDS1FVJ2R2T | 2.2 1/2W Δ | R612 | ERDS2TJ103T | 10K 1/4W | R697 | ERDS2TJ472T | 4.7K 1/4W |
| R433 | ERDS2TJ562T | 5.6K 1/4W | R530 | ERDS2TJ681T | 680 1/4W | R613 | ERDS2TJ102T | 1K 1/4W | R698 | ERDS2TJ682T | 6.8K 1/4W |
| R434 | ERDS2TJ562T | 5.6K 1/4W | R531 | ERDS2TJ151T | 150 1/4W | R614 | ERDS2TJ102T | 1K 1/4W | R699 | ERDS2TJ473T | 47K 1/4W |
| R435 | ERDS2TJ332T | 3.3K 1/4W | R532 | ERDS2TJ222T | 2.2K 1/4W | R616 | ERDS2TJ103T | 10K 1/4W | R700 | ERDS2TJ102T | 1K 1/4W |
| R436 | ERDS2TJ471T | 470 1/4W | R533 | ERDS2TJ472T | 4.7K 1/4W | R617 | ERDS2TJ106T | 10M 1/4W | R701 | ERDS2TJ102T | 1K 1/4W |
| R437 | ERDS2TJ224T | 220K 1/4W | R534 | ERDS1FVJ2R2T | 2.2 1/2W Δ | R618 | ERDS2TJ334T | 330K 1/4W | R702 | ERDS2TJ122T | 1.2K 1/4W |
| R438 | ERDS2TJ224T | 220K 1/4W | R535 | ERDS1FVJ2R2T | 2.2 1/2W Δ | R619 | ERDS2TJ681T | 680 1/4W | R703 | ERDS2TJ182T | 1.8K 1/4W |
| R441 | ERDS2TJ104T | 100K 1/4W | R537 | ERDS2TJ151T | 150 1/4W | R620 | ERDS2TJ472T | 4.7K 1/4W | R704 | ERDS2TJ222T | 2.2K 1/4W |
| R442 | ERDS2TJ682T | 6.8K 1/4W | R538 | ERDS1FVJ2R2T | 2.2 1/2W Δ | R621 | ERDS2TJ472T | 4.7K 1/4W | R705 | ERDS2TJ272T | 2.7K 1/4W |
| R443 | ERDS2TJ182T | 1.8K 1/4W | R539 | ERDS1FVJ390T | 39 1/2W Δ | R625 | ERDS2TJ101T | 100 1/4W | R706 | ERDS2TJ472T | 4.7K 1/4W |
| R444 | ERDS2TJ182T | 1.8K 1/4W | R540 | ERDS1FVJ330T | 33 Δ 1/2W(E) | R626 | ERDS2TJ101T | 100 1/4W | R707 | ERDS2TJ682T | 6.8K 1/4W |

| Ref No. | Part No. | Values & Remarks | Ref No. | Part No. | Values & Remarks | Ref No. | Part No. | Values & Remarks | Ref No. | Part No. | Values & Remarks |
|---------|-------------|------------------|---------|-------------------|------------------|---------|--------------|------------------|---------|--------------|------------------|
| R708 | ERDS2TJ103T | 10K 1/4W | R759 | ERDS2TJ820T | 82 1/4W | C28 | ECEA1HKA010B | 1 50V | C108 | ECEA1CKA330B | 33 16V |
| R709 | ERDS2TJ223T | 22K 1/4W | R760 | ERDS2TJ820T | 82 1/4W | C29 | ECFR1C103KR | 0.01 16V | C109 | ECEA1CKA101B | 100 16V |
| R711 | ERDS2TJ102T | 1K 1/4W | R761 | ERDS2TJ820T | 82 1/4W | C30 | ECFR1C103KR | 0.01 16V | C111 | ECBT1H561KB5 | 560P 50V |
| R712 | ERDS2TJ102T | 1K 1/4W | R762 | ERDS2TJ820T | 82 1/4W | C31 | ECBT1H150JC5 | 15P 50V | C112 | ECBT1H561KB5 | 560P 50V |
| R713 | ERDS2TJ122T | 1.2K 1/4W | R763 | ERDS2TJ820T | 82 1/4W | C32 | ECBT1C103MS5 | 0.01 16V | C113 | ECEA0JKA221B | 220 6.3V |
| R714 | ERDS2TJ182T | 1.8K 1/4W | R764 | ERDS2TJ820T | 82 1/4W | C33 | ECEA1HKA2R2B | 2.2 50V | C114 | ECEA0JKA221B | 220 6.3V |
| R715 | ERDS2TJ222T | 2.2K 1/4W | R765 | ERDS2TJ820T | 82 1/4W | C34 | ECEA1HKA010B | 1 50V | C115 | ECFR1C333JR | 0.033 16V |
| R716 | ERDS2TJ272T | 2.7K 1/4W | R766 | ERDS2TJ820T | 82 1/4W | C35 | ECEA1HKA010B | 1 50V | C116 | ECFR1C333JR | 0.033 16V |
| R717 | ERDS2TJ472T | 4.7K 1/4W | R767 | ERDS2TJ223T | 22K 1/4W | C36 | ECEA1HKA010B | 1 50V | C117 | ECEA1HKA010B | 1 50V |
| R718 | ERDS2TJ682T | 6.8K 1/4W | R768 | ERDS2TJ123T | 12K 1/4W | C37 | ECEA1HKA010B | 1 50V | C118 | ECEA1HKA010B | 1 50V |
| R719 | ERDS2TJ103T | 10K 1/4W | R769 | ERDS2TJ223T | 22K 1/4W | C38 | ECBT1C822MS5 | 8200P 16V | C119 | ECEA1HKA4R7B | 4.7 50V |
| R720 | ERDS2TJ223T | 22K 1/4W | R770 | ERDS2TJ123T | 12K 1/4W | C39 | ECBT1C822MS5 | 8200P 16V | C120 | ECEA1HKA4R7B | 4.7 50V |
| R721 | ERDS2TJ683T | 68K 1/4W | R771 | ERDS2TJ472T | 4.7K 1/4W | C40 | ECBT1H561KB5 | 560P 50V | C121 | ECEA1HKA010B | 1 50V |
| R722 | ERDS2TJ102T | 1K 1/4W | R773 | ERDS2TJ104T | 100K 1/4W | C41 | ECBT1H561KB5 | 560P 50V | C122 | ECEA1HKA010B | 1 50V |
| R723 | ERDS2TJ102T | 1K 1/4W | R774 | ERDS2TJ104T | 100K 1/4W | C42 | ECBT1C562MR5 | 5600P 16V | C123 | ECBT1H102KB5 | 1000P 50V |
| R724 | ERDS2TJ122T | 1.2K 1/4W | R775 | ERDS2TJ104T | 100K 1/4W | C43 | ECBT1C562MR5 | 5600P 16V | C124 | ECBT1H102KB5 | 1000P 50V |
| R725 | ERDS2TJ182T | 1.8K 1/4W | R780 | ERDS2TJ223T | 22K 1/4W | C44 | ECEA1CU101B | 100 16V | C125 | ECFR1C473MR | 0.047 16V |
| R726 | ERDS2TJ222T | 2.2K 1/4W | R788 | ERDS2TJ102T | 1K 1/4W | C45 | ECEA1HKA010B | 1 50V | C126 | ECFR1C473MR | 0.047 16V |
| R727 | ERDS2TJ272T | 2.7K 1/4W | R789 | ERDS2TJ102T | 1K 1/4W | C46 | ECEA1HKA010B | 1 50V | C127 | ECBT1C103MS5 | 0.01 16V |
| R728 | ERDS2TJ472T | 4.7K 1/4W | R790 | ERDS2TJ122T | 1.2K 1/4W | C47 | ECBT1H473ZF5 | 0.047 50V | C128 | ECBT1C103MS5 | 0.01 16V |
| R729 | ERDS2TJ682T | 6.8K 1/4W | R791 | ERDS2TJ1R2T | 1.2 1/4W | C48 | ECBT1H100JC5 | 10P 50V | C129 | ECBT1H821KB5 | 820P 50V |
| R730 | ERDS2TJ103T | 10K 1/4W | R792 | ERDS2TJ1R2T | 1.2 1/4W | C49 | ECBT1H331KB5 | 330P 50V | C130 | ECBT1H821KB5 | 820P 50V |
| R731 | ERDS2TJ223T | 22K 1/4W | R793 | ERDS2TJ1R2T | 1.2 1/4W | C51 | ECBT1C103MS5 | 0.01 16V | C131 | ECBT1H821KB5 | 820P 50V |
| R732 | ERDS2TJ683T | 68K 1/4W | R796 | ERDS2TJ102T | 1K 1/4W | C52 | ECEA25M4R7RB | 4.7 25V | C132 | ECBT1H821KB5 | 820P 50V |
| R733 | ERDS2TJ821T | 820 1/4W | R797 | ERDS2TJ102T | 1K 1/4W | C53 | ECBT1C103MS5 | 0.01 16V | C133 | ECEA1HKA4R7B | 4.7 50V |
| R734 | ERDS2TJ821T | 820 1/4W | R798 | ERDS2TJ102T | 1K 1/4W | C54 | ECBT1H180JC5 | 18P 50V | C134 | ECEA1HKA4R7B | 4.7 50V |
| R736 | ERDS2TJ102T | 1K 1/4W | R799 | ERDS2TJ102T | 1K 1/4W | C55 | ECBT1H150JC5 | 15P 50V | C135 | ECBT1H102KB5 | 1000P 50V |
| R737 | ERDS2TJ821T | 820 1/4W | R800 | ERDS2TJ561T | 560 1/4W | C56 | ECBT1H102KB5 | 1000P 50V | C136 | ECBT1H102KB5 | 1000P 50V |
| R738 | ERDS2TJ431T | 430 1/4W | R952 | ERDS2TJ821T | 820 1/4W | C57 | ECEA0JU101B | 100 6.3V | C137 | ECFR1C183KR | 0.018 16V |
| R739 | ERDS2TJ431T | 430 1/4W | R953 | ERDS2TJ393T | 39K 1/4W | C59 | ECBT1H330J5 | 33P 50V | C138 | ECFR1C183KR | 0.018 16V |
| R740 | ERDS2TJ221T | 220 1/4W | R972 | ERDS2TJ821T | 820 1/4W | C60 | ECBT1H102KB5 | 1000P 50V | C139 | ECEA1HKA2R2B | 2.2 50V |
| R741 | ERDS2TJ431T | 430 1/4W | R973 | ERDS2TJ393T | 39K 1/4W | C61 | ECBT1H331KB5 | 330P 50V | C140 | ECEA1CKA100B | 10 16V |
| R742 | ERDS2TJ221T | 220 1/4W | | | | C62 | ECEA1CU220B | 22 16V | C141 | ECEA1HKA0R1B | 0.1 50V |
| R743 | ERDS2TJ431T | 430 1/4W | | CAPACITORS | | C63 | ECBT1C103MS5 | 0.01 16V | C142 | ECFR1C223MR | 0.022 16V |
| R744 | ERDS2TJ104T | 100K 1/4W | C15 | ECBT1C103MS5 | 0.01 16V | C64 | ECBT1C103MS5 | 0.01 16V | C143 | ECEA1HKA4R7B | 4.7 50V |
| R745 | ERDS2TJ472T | 4.7K 1/4W | C16 | ECEA1CU220B | 22 16V | C65 | ECBT1H102KB5 | 1000P 50V | C144 | ECEA1HKA4R7B | 4.7 50V |
| R746 | ERDS2TJ472T | 4.7K 1/4W | C17 | ECBT1C103MS5 | 0.01 16V | C66 | ECBT1H102KB5 | 1000P 50V | C145 | ECEA1CKA100B | 10 16V |
| R747 | ERDS2TJ681T | 680 1/4W | C18 | ECBT1H102KB5 | 1000P 50V | C67 | ECBT1H102KB5 | 1000P 50V | C146 | ECEA1CKA100B | 10 16V |
| R749 | ERDS2TJ681T | 680 1/4W | C19 | ECBT1C103MS5 | 0.01 16V | C68 | ECBT1H102KB5 | 1000P 50V | C147 | ECBT1C152KR5 | 1500P 16V |
| R750 | ERDS2TJ681T | 680 1/4W | C20 | ECEA1HKA3R3B | 3.3 50V | C71 | ECBT1C103MS5 | 0.01 16V | C148 | ECBT1C152KR5 | 1500P 16V |
| R751 | ERDS2TJ681T | 680 1/4W | C21 | ECEA0JU101B | 100 6.3V | C72 | ECBT1H471KB5 | 470P 50V | C150 | ECEA1AKA470B | 47 10V |
| R752 | ERDS2TJ681T | 680 1/4W | C22 | ECBT1C103MS5 | 0.01 16V | C73 | ECBT1H2R7KC5 | 2.7P 50V | C151 | ECEA1HKA010B | 1 50V |
| R753 | ERDS2TJ681T | 680 1/4W | C23 | ECEA1CU220B | 22 16V | C101 | ECBT1H102KB5 | 1000P 50V | C152 | ECEA1HKA010B | 1 50V |
| R754 | ERDS2TJ681T | 680 1/4W | C24 | ECBT1H473ZF5 | 0.047 50V | C102 | ECBT1H102KB5 | 1000P 50V | C153 | ECBT1H102KB5 | 1000P 50V |
| R755 | ERDS2TJ681T | 680 1/4W | C25 | ECEA1HKA4R7B | 4.7 50V | C103 | ECBT1H681KB5 | 680P 50V | C154 | ECBT1H102KB5 | 1000P 50V |
| R756 | ERDS2TJ681T | 680 1/4W | C26 | ECBT1C822MS5 | 8200P 16V | C104 | ECFR1C223MR | 0.022 16V | C155 | ECEA1CKA100B | 10 16V |
| R757 | ERDS2TJ681T | 680 1/4W | C27 | ECQP1821JZT | 820P 100V[M] | C105 | ECBT1H681KB5 | 680P 50V | C156 | ECEA1CKA100B | 10 16V |
| R758 | ERDS2TJ681T | 680 1/4W | | | | C106 | ECBT1H681KB5 | 680P 50V | C161 | ECEA1CKA101B | 100 16V |

| Ref No. | Part No. | Values & Remarks | Ref No. | Part No. | Values & Remarks | Ref No. | Part No. | Values & Remarks | Ref No. | Part No. | Values & Remarks |
|---------|--------------|------------------|---------|--------------|------------------|---------|--------------|------------------|---------|--------------|-----------------------|
| C162 | ECEA1CU471B | 470 16V | C314 | ECFR1C473KR | 0.047 16V | C397 | ECBT1C472MR5 | 4700P 16V | C513 | ECKR1H223ZF5 | 0.022 50V |
| C163 | ECEA1HKA010B | 1 50V | C315 | ECBT1E103ZF5 | 0.01 25V | C398 | ECBT1C472MR5 | 4700P 16V | C514 | ECKR1H223ZF5 | 0.022 50V |
| C164 | ECEA1HKA010B | 1 50V | C316 | ECBT0J223NS5 | 0.022 6.3V | C401 | ECEA1CKA100B | 10 16V | C515 | ECKR1H103ZF5 | 0.01 50V |
| C165 | ECEA1CKA100B | 10 16V | C317 | ECEA1HKA3R3B | 3.3 50V | C402 | ECEA1AKA330B | 33 10V | C516 | ECKR1H103ZF5 | 0.01 50V |
| C166 | ECEA1CKA100B | 10 16V | C318 | ECEA1HKA3R3B | 3.3 50V | C403 | ECBT1E103ZF5 | 0.01 25V | C517 | ECEA1EU222E | 2200 25V |
| C167 | ECEA1HKAR68B | 0.68 50V | C320 | ECBT0J223NS5 | 0.022 6.3V | C404 | ECEA1CKA330B | 33 16V | C518 | ECKR1H103ZF5 | 0.01 50V |
| C168 | ECEA1HKAR68B | 0.68 50V | C321 | ECEA1HKA0R1B | 0.1 50V | C405 | ECBT1E103ZF5 | 0.01 25V | C519 | ECKR1H103ZF5 | 0.01 50V |
| C169 | ECEA1HKA4R7B | 4.7 50V | C322 | ECEA1HKA0R1B | 0.1 50V | C406 | ECBT1E103ZF5 | 0.01 25V | C520 | ECKR1H103ZF5 | 0.01 50V |
| C170 | ECEA1HKA4R7B | 4.7 50V | C323 | ECEA1HKAR22B | 0.22 50V | C407 | ECEA1AU470B | 47 10V | C521 | ECKR1H103ZF5 | 0.01 50V |
| C171 | ECEA1CKA100B | 10 16V | C324 | ECEA1HKAR22B | 0.22 50V | C408 | ECBT1E103ZF5 | 0.01 25V | C522 | ECEA1HU332 | 3300 50V [△] |
| C173 | ECBT1C103MS5 | 0.01 16V | C325 | ECFR1C153MR | 0.015 16V | C409 | ECEA1HKA3R3B | 3.3 50V | C523 | ECEA1HU332 | 3300 50V [△] |
| C174 | ECEA1HKA4R7B | 4.7 50V | C326 | ECFR1C153MR | 0.015 16V | C410 | ECEA1HU470B | 47 50V | C524 | ECEA0JU101B | 100 6.3V |
| C175 | ECEA1VU221B | 220 10V | C327 | ECFR1C153MR | 0.015 16V | C411 | ECKR1H103ZF5 | 0.01 50V | C528 | ECEA1AKA470B | 47 10V |
| C176 | ECQV1H473JZ3 | 0.047 50V | C328 | ECFR1C153MR | 0.015 16V | C412 | ECKR1H103ZF5 | 0.01 50V | C529 | ECBT1E103ZF5 | 0.01 25V |
| C177 | ECBT1H102KB5 | 1000P 50V | C329 | ECBT1C222MR5 | 2200P 16V | C413 | ECEA2AU470 | 47 100V | C536 | ECEA1CU101B | 100 16V |
| C178 | ECBT1H102KB5 | 1000P 50V | C330 | ECBT1C222MR5 | 2200P 16V | C414 | ECEA1AKA330B | 33 10V | C537 | ECBT1E103ZF5 | 0.01 25V |
| C179 | ECBT1C103MS5 | 0.01 16V | C331 | ECEA1HKA010B | 1 50V | C415 | ECBT1E103ZF5 | 0.01 25V | C538 | ECEA1CKA470B | 47 16V |
| C180 | ECBT1C103MS5 | 0.01 16V | C332 | ECEA1HKA010B | 1 50V | C416 | ECEA0JKA470B | 47 6.3V | C539 | ECBT1E103ZF5 | 0.01 25V |
| C181 | ECBT1C103MS5 | 0.01 16V | C333 | ECEA1HKA0R1B | 0.1 50V | C417 | ECBT1E103ZF5 | 0.01 25V | C551 | ECKR1H223ZF5 | 0.022 50V |
| C182 | ECEA1HKA4R7B | 4.7 50V | C334 | ECEA1HKA0R1B | 0.1 50V | C418 | ECA1EM102E | 1000P 25V | C552 | ECKR1H223ZF5 | 0.022 50V |
| C183 | ECQV1H474JZ3 | 0.47 50V | C335 | ECEA1HKA0R1B | 0.1 50V | C420 | ECBT1E103ZF5 | 0.01 25V | C553 | ECQE1224KF3 | 0.22 100V[M] |
| C184 | ECQP1152JZT | 1500P 100V[M] | C336 | ECEA1HKA0R1B | 0.1 50V | C421 | ECEA1HU100B | 10 50V | C559 | ECBT1E103ZF5 | 0.01 25V |
| C185 | ECQP2A472JZT | 4700P 100V | C337 | ECEA1HKA3R3B | 3.3 50V | C422 | ECBT1H102KB5 | 1000P 50V | C561 | ECEA1HKA2R2B | 2.2 50V |
| C186 | ECEA1AKA470B | 47 10V | C338 | ECEA1HKA3R3B | 3.3 50V | C423 | ECBT1C103MS5 | 0.01 16V | C562 | ECBT1E103ZF5 | 0.01 25V |
| C187 | ECBT1H101KB5 | 100P 50V | C339 | ECBT1E103ZF5 | 0.01 25V | C424 | ECBT1H102KB5 | 1000P 50V | C563 | ECEA1AU221B | 220 10V |
| C188 | ECBT1H101KB5 | 100P 50V | C340 | ECBT1E103ZF5 | 0.01 25V | C441 | ECBT1H220J5 | 22P 50V | C564 | ECBT1E103ZF5 | 0.01 25V |
| C189 | ECQP2A272JZT | 2700P 100V | C341 | ECEA1CKA220B | 22 16V | C442 | ECEA1HKA2R2B | 2.2 50V | C565 | ECEA1CKA100B | 10 16V |
| C190 | ECBT1C103MS5 | 0.01 16V | C342 | ECEA1HKA4R7B | 4.7 50V | C443 | ECBT1E103ZF5 | 0.01 25V | C566 | ECEA1CKA100B | 10 16V |
| C193 | ECBT1H102KB5 | 1000P 50V | C343 | ECEA1HKAR47B | 0.47 50V | C444 | ECBT1E103ZF5 | 0.01 25V | C567 | ECEA0JU471B | 470 6.3V |
| C194 | ECBT1H102KB5 | 1000P 50V | C344 | ECEA1HKAR47B | 0.47 50V | C451 | ECBT1E103ZF5 | 0.01 25V | C597 | ECBT1E103ZF5 | 0.01 25V |
| C201 | ECEA1CKA101B | 100 16V | C347 | ECBT1H560J5 | 56P 50V | C481 | ECBT1H101KB5 | 100P 50V | C599 | ECEA1HU470B | 47 50V |
| C202 | ECBT1H104ZF5 | 0.1 50V | C348 | ECBT1H560J5 | 56P 50V | C482 | ECBT1H101KB5 | 100P 50V | C601 | ECBT1H561KB5 | 560P 50V |
| C203 | ECBT1H331KB5 | 330P 50V | C351 | ECBT1E103ZF5 | 0.01 25V | C483 | ECBT1H101KB5 | 100P 50V | C602 | ECBT1H561KB5 | 560P 50V |
| C204 | ECBT1H331KB5 | 330P 50V | C352 | ECBT1E103ZF5 | 0.01 25V | C484 | ECBT1H101KB5 | 100P 50V | C604 | ECBT1H561KB5 | 560P 50V |
| C205 | ECBT1C222KR5 | 2200P 16V | C353 | ECEA1HKA3R3B | 3.3 50V | C485 | ECBT1H101KB5 | 100P 50V | C605 | ECBT1H561KB5 | 560P 50V |
| C206 | ECBT1C222KR5 | 2200P 16V | C354 | ECEA1HKA3R3B | 3.3 50V | C486 | ECBT1H101KB5 | 100P 50V | C606 | ECBT1H561KB5 | 560P 50V |
| C301 | ECBT1E103ZF5 | 0.01 25V | C355 | ECEA1HKAR33B | 0.33 50V | C501 | ECEA1HKA3R3B | 3.3 50V | C607 | ECBT1H561KB5 | 560P 50V |
| C302 | ECBT1E103ZF5 | 0.01 25V | C356 | ECEA1HKAR33B | 0.33 50V | C502 | ECEA1HKA3R3B | 3.3 50V | C608 | ECBT1H101KB5 | 100P 50V |
| C304 | ECBT0J223NS5 | 0.022 6.3V | C357 | ECEA0JKA470B | 47 6.3V | C503 | ECBT1H102KB5 | 1000P 50V | C609 | ECEA0JKA470B | 47 6.3V |
| C305 | ECBT1E103ZF5 | 0.01 25V | C359 | ECEA1HU010B | 1 50V | C504 | ECBT1H102KB5 | 1000P 50V | C610 | ECBT1C103MS5 | 0.01 16V |
| C306 | ECBT1E103ZF5 | 0.01 25V | C360 | ECEA0JKA470B | 47 6.3V | C505 | ECBT1H331KB5 | 330P 50V | C613 | ECEA1HKA010B | 1 50V |
| C307 | ECBT1H101KB5 | 100P 50V | C361 | ECEA1HKA010B | 1 50V | C506 | ECBT1H331KB5 | 330P 50V | C614 | ECEA1HKA010B | 1 50V |
| C308 | ECBT1H101KB5 | 100P 50V | C362 | ECBT1H101KB5 | 100P 50V | C507 | ECBT1H150J5 | 15P 50V | C615 | ECBT1H150JC5 | 15P 50V |
| C309 | ECBT1H104ZF5 | 0.1 50V | C363 | ECBT1H101KB5 | 100P 50V | C508 | ECBT1H150J5 | 15P 50V | C616 | ECBT1H180JC5 | 18P 50V |
| C310 | ECBT1H104ZF5 | 0.1 50V | C364 | ECFR1C104MR | 0.1 16V | C509 | ECEA1HKA010B | 1 50V | C617 | ECBT1H680J5 | 68P 50V |
| C311 | ECBT1H470J5 | 47P 50V | C392 | ECBT1H100JC5 | 10P 50V | C510 | ECEA1HKA010B | 1 50V | C618 | ECBT1H560J5 | 56P 50V |
| C312 | ECBT1H470J5 | 47P 50V | C393 | ECQV1H473JZ3 | 0.047 50V | C511 | ECEA1HU330B | 33 50V | C619 | ECBT1H680J5 | 68P 50V |
| C313 | ECBT1H104ZF5 | 0.1 50V | C394 | ECQV1H473JZ3 | 0.047 50V | C512 | ECEA2AU100B | 10 100V | C620 | ECBT1H560J5 | 56P 50V |

| Ref.No. | Part No. | Values & Remarks | Ref.No. | Part No. | Values & Remarks | Ref.No. | Part No. | Values & Remarks | Ref.No. | Part No. | Values & Remarks |
|---------|---------------|------------------|---------|--------------|------------------|---------|--------------|------------------|---------|-----------------|------------------|
| C621 | ECEA1HKA3R3B | 3.3 50V | R707 | ERJ6GEYJ474V | 470K 1/10W | C711 | ECUZNE104MBN | 0.1 25V | RJ721 | ERJ8GEY0R00A | 0 1/8W |
| C622 | ECEA1VKA100B | 10 10V | R708 | ERJ6GEYJ154V | 150K 1/10W | C712 | ECUZNE104MBN | 0.1 25V | RJ722 | ERJ8GEY0R00A | 0 1/8W |
| C623 | ECEA1VKA100B | 10 10V | R709 | ERJ6GEYJ683V | 68K 1/10W | C713 | ECUV1C104MBM | 0.1 16V | RJ723 | ERJ8GEY0R00A | 0 1/8W |
| C624 | ECEA0JKA101B | 100 6.3V | R711 | ERJ6GEYJ154V | 150K 1/10W | C714 | ECEA0JKA101I | 100 6.3V | RJ724 | ERJ8GEY0R00A | 0 1/8W |
| C625 | ECBT1H102KB5 | 1000P 50V | R712 | ERJ6GEYJ221V | 220 1/10W | C716 | ECUV1H561KBN | 560P 50V | RJ725 | ERJ8GEY0R00A | 0 1/8W |
| C626 | ECEA0JU102B | 1000 6.3V | R717 | ERJ6GEYJ102V | 1K 1/10W | C717 | ECUZNE104MBN | 0.1 25V | RJ726 | ERJ8GEY0R00A | 0 1/8W |
| C627 | ECEA0JU102B | 1000 6.3V | R718 | ERJ6GEYJ102V | 1K 1/10W | C718 | ECUV1C224KBN | 0.22 16V | RJ727 | ERJ8GEY0R00A | 0 1/8W |
| C628 | ECBT1H102KB5 | 1000P 50V | R719 | ERJ6GEYJ102V | 1K 1/10W | C721 | ECUV1H150JCN | 15P 50V | RJ728 | ERJ8GEY0R00A | 0 1/8W |
| C629 | ECBT1H101KB5 | 100P 50V | R720 | ERJ6GEYJ102V | 1K 1/10W | C722 | ECUV1H150JCN | 15P 50V | RJ729 | ERJ8GEY0R00A | 0 1/8W |
| C630 | ECBT1H101KB5 | 100P 50V | R721 | ERJ6GEYJ101V | 100 1/10W | C723 | ECEA1AKA221I | 220 10V | RJ730 | ERJ8GEY0R00A | 0 1/8W |
| C631 | ECBT1C103MS5 | 0.01 16V | R722 | ERJ6GEYJ563V | 56K 1/10W | C724 | ECUV1C104MBM | 0.1 16V | | | |
| C647 | ECBT1C103MS5 | 0.01 16V | R723 | ERJ6GEYJ182V | 1.8K 1/10W | C725 | ECUV1H102KBN | 1000P 50V | | TEST JUMPERS | |
| C648 | ECEA1HKA010B | 1 50V | R724 | ERJ6GEYJ333V | 33K 1/10W | C726 | ECUV1H102KBN | 1000P 50V | | | |
| C654 | ECEA1AU221B | 220 10V | R725 | ERJ6GEYJ472V | 4.7K 1/10W | C727 | ECEA1HPK010I | 1 50V | TJ701 | EYF8CU | TEST JUMPER |
| C655 | ECEA1HKA010B | 1 50V | R726 | ERJ6GEYJ473V | 47K 1/10W | C728 | ECEA1HPK010I | 1 50V | TJ702 | EYF8CU | TEST JUMPER |
| C656 | ECBT1H102KB5 | 1000P 50V | R727 | ERJ6GEYJ822V | 8.2K 1/10W | C730 | ECUZNE104MBN | 0.1 25V | | | |
| C657 | ECBT1C103MS5 | 0.01 16V | R728 | ERJ6GEYJ103V | 10K 1/10W | C731 | ECEA0JKA221I | 220 6.3V | | <LOADING MOTOR> | |
| C658 | ECEA1CKA100B | 10 16V | R731 | ERJ6GEYJ822V | 8.2K 1/10W | C732 | ECEA0JKA221I | 220 6.3V | | CAPACITOR | |
| C665 | ECBT1C332MR5 | 3300P 16V | R734 | ERJ6GEYJ101V | 100 1/10W | C733 | ECUZNE104MBN | 0.1 25V | | | |
| C673 | ECBT1H102KB5 | 1000P 50V | R735 | ERJ6GEYJ101V | 100 1/10W | C734 | ECEA1AKA221I | 220 10V | C1 | ECA1AKF820E | 82 10V |
| C674 | ECBT1H102KB5 | 1000P 50V | R736 | ERJ6GEYJ101V | 100 1/10W | C735 | ECUZNE104MBN | 0.1 25V | | | |
| C675 | ECBT1C103MS5 | 0.01 16V | R738 | ERJ6GEYJ223V | 22K 1/10W | C736 | ECUZNE104MBN | 0.1 25V | | | |
| C676 | ECBT1C103MS5 | 0.01 16V | R741 | ERJ6GEYJ562V | 5.6K 1/10W | C737 | ECUZNE104MBN | 0.1 25V | | | |
| C677 | ECBT1H561KB5 | 560P 50V | R742 | ERJ6GEYJ562V | 5.6K 1/10W | C738 | ECUV1C154KBN | 0.15 16V | | | |
| C678 | ECBT1H561KB5 | 560P 50V | R743 | ERJ6GEYJ562V | 5.6K 1/10W | C742 | ECUV1E273KBN | 0.027 25V | | | |
| C679 | ECBT1H104ZF5 | 0.1 50V | R744 | ERJ6GEYJ103V | 10K 1/10W | C743 | ECUZNE104MBN | 0.1 25V | | | |
| C680 | ECBT1H101KB5 | 100P 50V | R745 | ERJ6GEYJ155V | 1.5M 1/10W | C744 | ECUV1E822KBN | 8200P 25V | | | |
| C681 | ECBT1H101KB5 | 100P 50V | R748 | ERJ6GEYJ182V | 1.8K 1/10W | C745 | ECUV1C473MBN | 0.047 16V | | | |
| C682 | ECBT1H104ZF5 | 0.1 50V | R749 | ERJ6GEYJ682V | 6.8K 1/10W | C747 | ECUV1H222KBN | 2200P 50V | | | |
| C683 | ECBT1H331KB5 | 330P 50V | R750 | ERJ6GEYJ473V | 47K 1/10W | C748 | ECUV1H471KBM | 470P 50V | | | |
| C684 | ECBT1H331KB5 | 330P 50V | R751 | ERJ6GEYJ473V | 47K 1/10W | C749 | ECUZNE104MBN | 0.1 25V | | | |
| C687 | ECBT1H102KB5 | 1000P 50V | R752 | ERJ8GEYJ220V | 22 1/8W | C751 | ECUZNE104MBN | 0.1 25V | | | |
| C688 | ECBT1H102KB5 | 1000P 50V | R770 | ERJ6GEYJ155V | 1.5M 1/10W | C752 | ECUV1H152KBN | 1500P 50V | | | |
| C689 | ECEA1AKA220B | 22 10V | R771 | ERJ6GEYJ155V | 1.5M 1/10W | C753 | ECUV1H471KBM | 470P 50V | | | |
| C694 | ECBT0J223NS5 | 0.022 6.3V | R772 | ERJ6GEYJ273V | 27K 1/10W | C754 | ECUV1H471KBN | 470P 50V | | | |
| C696 | ECBT1H471KB5 | 470P 50V | | | | | | | | | |
| C697 | ECBT1H331KB5 | 330P 50V | | CAPACITORS | | | CHIP JUMPERS | | | | |
| C698 | ECBT1E103ZF5 | 0.01 25V | | | | | | | | | |
| C699 | ECKR1H102KBD | 1000P 50V | C701 | ECEA0JKA330I | 33 6.3V | RJ701 | ERJ8GEY0R00A | 0 1/8W | | | |
| | | | C702 | ECUZNE104MBN | 0.1 25V | RJ702 | ERJ8GEY0R00A | 0 1/8W | | | |
| | <SERVO P.C.B> | | C703 | ECEA0JKA101I | 100 6.3V | RJ703 | ERJ8GEY0R00A | 0 1/8W | | | |
| | RESISTORS | | C704 | ECUZNE104MBN | 0.1 25V | RJ704 | ERJ8GEY0R00A | 0 1/8W | | | |
| | | | C705 | ECUZNE104MBN | 0.1 25V | RJ707 | ERJ8GEY0R00A | 0 1/8W | | | |
| R701 | ERJ6GEYJ4R7V | 4.7 1/10W | C706 | ECUV1H272KBN | 2700P 50V | RJ709 | ERJ8GEY0R00A | 0 1/8W | | | |
| R703 | ERJ6GEYJ823 | 82K 1/10W | C707 | ECUV1E273KBN | 0.027 25V | RJ714 | ERJ8GEY0R00A | 0 1/8W | | | |
| R704 | ERJ6GEYJ102V | 1K 1/10W | C708 | ECUV1H472KBN | 4700P 50V | RJ715 | ERJ8GEY0R00A | 0 1/8W | | | |
| R705 | ERJ6GEYJ103V | 10K 1/10W | C709 | ECUV1C473KBN | 0.047 16V | RJ716 | ERJ8GEY0R00A | 0 1/8W | | | |
| R706 | ERJ6GEYJ102V | 1K 1/10W | C710 | ECUV1H182KBN | 1800P 50V | RJ717 | ERJ8GEY0R00A | 0 1/8W | | | |

865

Packing Materials & Accessories

- Notes:**
- Important safety notice : Components identified by Δ mark have special characteristics important for safety. Furthermore, special parts which have purposes of fire-retardant (resistors), high-quality sound (capacitors), low-noise (resistors), etc. are used. When replacing any of components, be sure to use only manufacturer's specified parts shown in the parts list.
 - The parenthesized indications in the Remarks column specify the areas. (refer to the cover page for area.) Parts without these indications can be used for all areas.
 - [M] indicates in Remarks column parts that are supplied by MESA.
 - [VRD] indicates in Remarks column parts that are supplied by Video Recorder Division.
 - The "(SF)" mark denotes the standard part.
 - Remote Control Unit : Supply period for three years from terminal of production.
 - **Warning:** This product uses a laser diode. Refer to caution statements on page 3.
- ACHTUNG :**
- Die lasereinheit nicht zerlegen.
 - Die lasereinheit darf nur gegen eine vom hersteller spezifizierte einheit ausgetauscht werden.

| Ref No. | Part No. | Part Name & Description | Remarks | Ref No. | Part No. | Part Name & Description | Remarks | Ref No. | Part No. | Part Name & Description | Remarks |
|---------|-----------|--------------------------|---------|---------|-------------|-------------------------|---------|---------|------------|---------------------------------|---------|
| | | PACKING MATERIALS | | | | ACCESSORIES | | | | | |
| P1 | RPF0100 | BAG (SET) | [M] | A1 | EUR643804 | REMOTE CONTROL | [M] | A4 | RSA0010 | AM LOOP ANT | |
| P2 | RPG2796 | PACKING CASE | [M] | A2 | RFKSACH74EK | INSTRU MNL ASS'Y | [M](E) | A5 | RJA0019-2K | AC CORD (SF) (E,EG) Δ | |
| P3 | RPN0922-2 | POLYFOAM | [M] | A2 | RQT3309-B | INSTRUCTION MANUAL | [M](EB) | A5 | VJA0733 | AC CORD Δ (SF) [VRD](EB) | |
| P4 | SPSD155 | ACCESSORY CASE | | A2 | RQT3311-1D | INSTRUCTION MANUAL | [M](EG) | A6 | SJP9009 | ANT ADAPTER (EB) | |
| P5 | SPB1061 | VINYL BAG | | A3 | RSA0007 | FM ANTENNA | | | | | |

Packaging

P4 (SPSD155) : ACCESSORY CASE

A1 (EUR643804) : REMOTE CONTROL

P5 (SPB1061) : VINYL BAG

A2 (RFKSACH74EK ... E) : INSTRUCTION MANUAL ASS'Y
 A2 (RQT3309-B ... EB) : INSTRUCTION MANUAL
 A2 (RQT3311-1D ... EG) : INSTRUCTION MANUAL
 A3 (RSA0007) : FM ANTENNA
 A4 (RSA0010) : AM LOOP ANTENNA SET
 A5 (RJA0019-2K ... E,EG) : AC CORD
 A6 (SJP9009 ... EB) : ANTENNA ADAPTER

For only EB area
 • Put the AC power supply cord (VJA0733) on the top rear polyfoam.

P3 (RPN0922) — *P3 (A)
 *P3 (B)
 *P3 (C)
 *P3 (D)

